

In response to the state of emergency in Georgia regarding COVID-19 ("Coronavirus"), the Planning Commission meeting will be held via a "WebEx" online meeting platform, which will be broadcast on YouTube [<https://youtu.be/jb3zIW0-Aho>]. Members of the public may provide emailed comments at planning@accgov.com prior to 12:00 noon on the day before the meeting. Members of the public may also address the Planning Commission via electronic communication provided in the Auditorium at 120 West Dougherty Street, subject to safe distancing measures.

ATHENS-CLARKE COUNTY PLANNING COMMISSION
FINAL AGENDA
NOVEMBER 9, 2020 - 6:00 P.M.
120 W. Dougherty Street

GENERAL BUSINESS

1. Introduction of Staff reports and all other documents submitted to the Planning Commission at this meeting into the official record
2. MACORTS review and public comment

NEW BUSINESS

1. **OLD ELBERTON ROAD – PD-2020-10-2876**

Type I – Preliminary Planned Development

Petitioner: Johnny Tumlin

Owner: FAE Clarke, LLC

Request: From AR (Agricultural Residential) to C-R/RS-8 (PD) (Commercial-Rural/Single-Family Residential, Planned Development)

Tax ID: p/o 273 001

2. **175 TRACY STREET – PD-2020-10-2863**

Type II – Preliminary Planned Development

Petitioner: Brett Nave / Studio BNA, Inc.

Owner: 635 Barber Street, LLC

Request: From E-I (Employment-Industrial) to E-O (PD) (Employment-Office, Planned Development)

Tax ID: 114B 002B

3. **100 NEWTON BRIDGE ROAD – PD-2020-10-2875**

Type II – Preliminary Planned Development

Petitioner: Ed Lane / Smith Planning Group

Owner: Westclox Rocks, LLC

Request: From I (Industrial) to E-O (PD) (Employment-Office, Planned Development)

Tax ID: 112 003

4. **TEXT AMENDMENTS** – North Downtown Design Area (discussion only)

OTHER BUSINESS

1. Planning Commission Chair's Report
2. Planning Director's Report
3. Miscellaneous announcements

NOTICE

A qualified interpreter for the hearing impaired is available upon requests at least ten (10) days in advance of this meeting. Please call (706) 613-3515, [TDD (706) 613-3115] to request an interpreter.

STAFF REPORT
Preliminary Planned Development
CASE NUMBER PD-2020-10-2876
Old Elberton Road
November 9, 2020

GENERAL INFORMATION AND PROPOSED DEVELOPMENT

I. THE REQUEST

APPLICANT..... Johnny Tumlin
 OWNER..... Freida Ewing
 ZONING REQUEST From AR (Agricultural Residential) to CR/RS 8(PD)
 (Commercial Rural/Single-Family Residential,
 Planned Development)
 TYPE OF REQUEST..... Type I
 LOCATION Old Elberton Road
 COUNTY COMMISSION DISTRICT 1
 SIZE OF REZONING AREA..... 233.02 acres
 PRESENT USE..... Undeveloped
 PROPOSED USE..... Single-Family residential/multifamily residential/
 commercial
 TAX MAP NUMBER..... p/o 273 001
 ADJACENT USES AND ZONING (N) Single Family Residential / AR (Agricultural
 Residential)
 (S) Middle School /Government (G)
 (E) Single-Family residential / AR (Agricultural
 Residential)
 (W) (across Old Elberton Road) / Vacant / E-I
 (Employment-Industrial)
 STAFF RECOMMENDATION: Receive with comments
 PLANNING COMM. RECCOMENDATION..... Pending

II. PURPOSE

The purpose of this request is for a request for a Planned Development on Old Elberton Road. The plan calls for the splitting of 233.02 acre tract from a single 366.75 acre tract for the construction of single-family dwellings, multifamily dwellings and commercial uses. The proposal does not meet several of the development standards of the zoning code, therefore the Applicant has submitted the Planned Development request. A planned development includes a binding application report, site plan, and architectural elevations as a guarantee to the community that what is proposed would be constructed.

III. EXISTING CONDITIONS OF SUBJECT PROPERTY AND VICINITY

The subject property is located along Old Elberton Road, between Moores Grove Road and Lem Edwards Road, just north of the Old Elberton Road intersection with Pittard Road. This site is not located within a local historic district, nor is it designated a local historic landmark.

The subject property has several stream branches and creeks running through the property, as well as a lake and a pond. The topography suggests that the site is relatively flat, except along the streams. The land has both pasture and forest, with a forested corridor running through the center of the property. It currently has a conservation use tax designation.

Surrounding properties are zoned AR (Agricultural Residential) to the north, east and south; G (Government) to the south for Coile Middle School; and, E-I (Employment-Industrial) to the east across Old Elberton Road.

IV. PROPOSED DEVELOPMENT

The request is to rezone the property from AR (Agricultural Residential) to C-R/RS-8 (PD) (Commercial-Rural/Single-Family Residential, Planned Development). The 233.02 acre subject property would be split from a single 366.75 acre tract for the construction of 195 (front-loaded) detached single-family houses, 261 (alley-loaded) single-family detached houses, 141 Townhouse style single-family attached dwellings, 56 duplex/quadplex units, 12 bungalow/cottage court homes, 46 corner “manor house” stacked units, 71 walk-up apartments and 34 residential units over commercial on the ground floor. A six-plex is also denoted within the application report. Nonresidential uses consist of general office space, a shopping center and a day care center.

The non-residential uses would be clustered in the southwest corner of the proposed development. The multifamily dwellings are distributed throughout the development with the primary congregation in the southwest corner to be zoned C-R and three smaller congregations placed throughout the proposed RS-8 zone. The C-R zone allows 16 beds per acre. The plan denotes 475 beds, which is 85 beds over the allowed density. A waiver is being requested for this difference. Although the plan denotes a density count for multifamily, multifamily dwellings are prohibited in single-family residential zones; therefore, the RS-8 zone does not have a maximum density standard for multifamily dwellings.

The application report denotes on-street parking, shared parking areas, individual driveways, and possible garage parking for the single-family units. The plan shows that within the C-R zone 114 spaces are provided for the commercial uses; 148 spaces for multifamily; 137 on-street parking spaces; and, the single-family attached units have garage parking. Within the RS-8 zone, 172 parking spaces are provided for the multifamily; 377 on-street parking spaces; and, again, the single-family attached units have garage parking. No parking spaces are denoted for the single-family detached houses.

Photographic examples and conceptual site plans are included within the application report for the various dwelling types. The residences would be two- and three-stories in height, and the architectural style is denoted as Southern vernacular with contemporary and traditional features. Architectural illustrations and descriptions about the proposed commercial buildings are lacking.

The application report states that nearly 40% of the site will be open space, including 31 acres of conserved tree canopy, but the plan indicates that open space will make up 45% of the entire site (105 acres). C-R zone property is required to have 30% conserved tree canopy, while RS-8 zoning requires 15% conserved tree canopy. Combined, this equals 38 acres. A waiver has been requested to reduce the conserved tree canopy to 31 acres (13.3%).

The application report denotes a phasing plan. Phase I would be in the southwest quarter of the development and consist of commercial, multifamily and single-family uses. Phase 2 would consist of the remaining multifamily dwellings in the southwest quarter, as well as single-family and multifamily dwellings. Phase 3 would develop the northern half of the property with single-family and multifamily dwellings.

The application report states that stormwater management and water quality will be handled within a number of stormwater ponds located throughout the site. Two existing and seven proposed ponds are shown on the plan as being distributed throughout the subject property. The maximum allowable lot coverage in both the C-R and RS-8 districts for individual lots is 35% and 45% respectfully. A waiver has been requested to apply one maximum lot coverage percentage across the development, but the request does not specify the proposed percentage.

COMPATIBILITY WITH COMPREHENSIVE PLAN

I. COMPATIBILITY WITH FUTURE LAND USE MAP

The Future Land Use Map indicates that the subject parcel has a *Rural* designation, which is described as follows:

Rural lands are intended to have a very low residential density. To maintain open space, clustering of dwellings is encouraged with common open spaces protected by conservation easements. Agricultural uses are encouraged, as well as other compatible uses, such as limited, low-impact commercial uses, equestrian and other animal boarding facilities.

The proposed RS-8 zoning district is not compatible with the *Rural* Future Land Use designation, per the Compatibility Matrix in ACC Code Chapter 9-4. Staff disagrees with the application report contention that one purpose of the greenbelt is to foster infill development since the Compatibility Matrix designates only AR (Agricultural Residential) zoning as the only residential district compatible with the *Rural* designation. The two cited examples of smaller lot subdivisions in the *Rural* area are also incorrect; neither Lantern Walk nor Snapfinger have a *Rural* designation. Although the proposed C-R (Commercial-Rural) zoning designation is compatible with the *Rural* designation, the proposed development is not compatible with the C-R zoning district as evidenced by the number of required waivers. More intensive residential and commercial zoning designations, along with a compatible Future Land Use designation, should be considered for the proposed mixed-use type of development.

II. COMPATIBILITY WITH VISION STATEMENTS, ISSUES AND OPPORTUNITIES & POLICIES

Relevant Comprehensive Plan Goals and Strategies are as follows:

- Goal: Housing options that reflect the diversity and meet the needs of the community, including housing for families and a diverse workforce. These are quality options with a variety of types, prices, and locations.
- Strategy: Increase amount of and provide access to affordable housing.
- Strategy: Utilize neighborhood schools as hubs for diverse school and neighborhood engagement. Schools are a natural, central location for effective community interaction and service delivery.

COMPATIBILITY WITH ZONING MAP AND ORDINANCE STANDARDS

I. COMPATIBILITY WITH ZONING MAP

The purpose of this request is rezone a parcel from AR (Agricultural Residential) to CR/RS-8 (PD) (Commercial-Rural/Single-Family Residential, Planned Development).

As previously noted, Staff does not find these proposed zoning categories to be compatible with the intensity and uses of the proposed development, as evidenced by the number of needed waivers. The proposed residential zoning district should reflect the types and intensity of all proposed residential uses – single-family, duplex and multifamily – which would be an RM (Mixed Density Residential) classification. Similarly, the proposed commercial zoning district should reflect the types and intensity of all proposed commercial uses. The proposed “Village Center” urban-type development is not compatible with the C-R (Commercial-Rural) development regulations, whose large lot sizes, building setbacks and lot coverages are better suited to areas without sanitary sewer service.

II. COMPATIBILITY WITH ORDINANCE STANDARDS

All exemptions to the zoning and development standards must be identified in the application prior to approval of a binding proposal since the development will otherwise be expected to adhere to the ordinance standards. The following 10 waivers have been requested:

1. *Waiver from Section 8-7-15-d, which requires C-R zones conserve 30% canopy and RS-8 conserve 15% canopy.*
A waiver has been requested to eliminate 100% of the conserved canopy in the proposed C-R portion of the development and a 1% reduction in the proposed RS-8 portion.
2. *Waiver from Section 9-7-2 and 9-10-2, which allows lots in RS-8 zones to have a maximum coverage of 45% and lots in C-R zones a maximum coverage of 35%.*
The waiver being requested is to allow more coverage on each lot. The proposed justification for the waiver is that it cannot and should not be calculated on a lot by lot basis, but over the whole development. However, no maximum lot coverage calculation has been provided.
3. *Waiver from Section 9-7-2, which does not allow multi-family housing within single-family zoning.*
A waiver is being requested to allow separate multi-family housing types (duplex, tri-plex, quad-plex, etc.) within the proposed RS-8 zoning district. Staff finds this waiver request to be unnecessary since other zoning designations would allow all of the proposed housing types. Furthermore, since multifamily dwellings are not allowed in RS zones, the Code lacks density and design standards for their placement in such zones.
4. *Waiver from Section 9-10-2, which requires first floor commercial space for multifamily dwellings in “C” zones.* The waiver is being requested to allow some of the multifamily dwellings within the proposed C-R zone portion to not have a commercial component.
5. *Waiver from Section 9-10-3, which allows 16 beds per acre in the C-R zone.*
The waiver is being requested to increase the density within the C-R zone from 16 beds to 20 beds per acre.

6. *Waiver from Section 9-10-3, which requires the front yard setback in the proposed C-R zone to be a minimum of 20'.*
The waiver is being requested to reduce the minimum setback from 20' to a 0' setback in the proposed C-R zone. The request states that this would improve the walkability and viability of the commercial spaces on the site.
7. *Waiver from Section 9-10-3, which requires 65% landscaped area on each parcel within the C-R zone.*
The waiver is being requested to allow the landscaped areas to be concentrated within the planned open spaces rather than on the parcels within the C-R zone.
8. *Waiver from Section 9-15-15, which requires 1,000 sq. ft of heated floor space for a residence.*
The waiver is being requested to allow the reduction in required heated floor space of 1,000 sq. ft. to be reduced to a minimum 700 sq. ft. Staff notes that the RM zone minimum is 600 sq. ft.
9. *Waiver from Section 9-25-8-B-5 (the application report states this section as 9-25-8-B-4), which requires direct access from a public street or sidewalk to a house entrance.*
The waiver is being requested due to several blocks of housing served only by an alley with greenspace in the front yard. For these lots, there will be no direct access to public streets.
10. *Waiver from Section 9-26-2-A-6-d-2, which requires that land disturbance activity shall be limited by permit only to those grading and clearing activities within the areas identified on the preliminary plat as street rights-of-way, water and sanitary sewer easements, and stormwater management facilities. Also included in the limited grading and clearing is 15' on either side of street rights-of-way, an additional ten feet on either side of water, sanitary sewer and stormwater line easements, and an additional ten feet around stormwater management facilities.*
The waiver is being requested is to allow mass grading without an acreage limitation.

More information is required on the binding site plan per the Planned Development requirements of Sec. 9-14-3(C), such as a vicinity map, street pavement and R/W widths, property line dimensions, and the tax parcel numbers and zoning designations of adjacent properties.

EFFECT ON COMMUNITY

I. BALANCE OF LAND USES IN ATHENS-CLARKE COUNTY

The proposed Planned Development has a combination of residential and commercial uses. The commercial component of the site will include a daycare center, general office and a proposed shopping center, which would not affect the balance of land uses in Athens-Clarke County; however, this would be the first introduction of commercial development in the immediate vicinity.

The application proposes that 20% of the dwelling units, rented or purchased, be affordable. However, no regulatory mechanism is currently in place in Athens-Clarke County to ensure compliance.

Other properties in the immediate vicinity have E-I (Employment-Industrial) zoning. Staff has significant concerns with a potential negative deterrence on additional investment in the development or redevelopment

for nearby industrial properties due to perceived negative impacts (noise, odors, vibration, etc.) on the future residents.

II. POPULATION

This proposal includes the construction of 232 attached units equaling 475 beds in the C-R portion of the property and 584 dwelling units in the RS-8 portion of the property. This is a high density development that will dramatically increase the population in the area.

III. ENVIRONMENT

The Athens-Clarke County Environmental Areas Map indicates a stream and associated riparian buffer along the northern portion of the parcel. Riparian buffers also exist in the southwest corner of the parcel. A lake and pond are also found on the property. The middle of the property, where the riparian buffers are, hosts a lush tree canopy. Many acres of trees are spread throughout the site creating habitat for an array of flora and fauna. Many acres of pasture land also cover a significant portion of the site.

The Athens-Clarke County Arborist has reviewed the tree management plan submitted as part of this request and has the following comments:

- A Tree Management Plan was not provided for the project, but tree data is shown in a general form. The plans show street plantings in the verge and, subsequently, in the rights-of-way, which is not the standard practice throughout Athens Clarke County. Street sections shown to scale would be helpful as the ones provided do not represent the plan accurately and show very immature trees.
- As it is drawn, the multi-family and commercial structures appear to be too close to street trees. Behind all of those structures are parking lots, which provide little to no wiggle room for the structures to meet adequate separation from the trees. The alley-loaded single family lots are also very tight in regards to large canopy street trees with the corner lots being nearly unbuildable once the required large canopy trees are taken into consideration. The layout and sizes should be considered at this time, tree figures adjusted if necessary, and, potentially, a waiver requested to allow medium canopy street trees.
- In regards to the conserved canopy waiver, Staff can agree for the required 38 acres of conserved canopy to be spread throughout the development; however, it seems that amount should be met in what is currently a rural greenfield setting. It also appears that if the lots were situated differently, then more canopy could be conserved
- Athens Clarke County is committed to greater species diversity for post construction planting as projects commonly use only a few trees from the ACC Tree Species list on all projects. A binding list of trees to be used and/or a commitment lower percentages of any given tree could benefit this project and the community.

IV. TRAFFIC, TRANSPORTATION, & TRANSIT

There are three 2-way curb cuts proposed onto Old Elberton Road. The provided Trip Generation Summary indicates that a total of 8,071 trips per day should be assumed once this project has been fully built out – a timeframe of six years.

According to the application report, a Traffic Impact Analysis (TIA) is currently in progress and will be available at the Master Plan stage. Preliminary findings of the TIA suggest that a roundabout or traffic signal should be installed at the intersection of Voyles/Old Elberton/Moores Grove/Spring Valley Roads in order to accommodate the peak hours of traffic produced from the anticipated increase in traffic.

The application report states that from the western corner of the site, it is a five-minute walk (usually found from the 0.25 mile mark) to the nearest transit stop. A sidewalk network does not exist within the vicinity of the site. The developer anticipates working with ACC Transit for a possible bus stop. However, at this time, ACC Transit does not serve Old Elberton Road.

There is also an issue regarding the Transportation Corridor Concept Map (TCC), which shows a planned minor collector from Charlie Bolton Road to Old Elberton Road running through the subject property. The application report states that, since there will be a subdivision of the current 366.75-acre parent tract into two parcels, enough room on the other parcel will be available to accommodate the planned road. Staff notes that the road is planned to intersect with Old Elberton Road about midway between Lem Edwards Road and Pittard Road, thus requiring the proposed development to either incorporate the corridor into the proposed street network or to reserve sufficient open space for later construction.

The Athens-Clarke County Department of Transportation and Public Works has reviewed the proposal and has the following comment:

- A Traffic Impact Study is required to be submitted with the Master Plan submittal.

V. GRADING AND DRAINAGE

There are seven stormwater management ponds being proposed on the site. The parameters and details of these management ponds will be designed and engineered during site construction and will be subject to final grading, soil conditions and feasibility.

As indicated in the waiver section, the application includes a request to allow mass grading.

VI. WATER AND SEWER AVAILABILITY

ACC sanitary sewer is not currently available to the subject property. The Public Utilities Department would have to pre-approve a sanitary sewer extension along Old Elberton Road. The Mayor and Commission would have to approve the proposed lift station and force main.

VII. FIRE PROTECTION

The Athens-Clarke County Fire Marshal has reviewed this request and has the following comments:

- ACCFES can provide fire protection without any fire services being affected or additional cost for fire equipment or personnel.
- Additional fire hydrants are needed.
- Fire apparatus can access the project. A turnaround is not needed.
- Apartment buildings will need to be sprinkled.

RECOMMENDATIONS

I. STAFF RECOMMENDATION - Receive with Comments

The purpose of the planned development request is rezone a large portion of an AR (Agricultural-Residential) tract off of Old Elberton to C-R/RS-8 (PD) (Commercial-Rural/Single-Family Residential, Planned Development) for commercial, single-family and multi-family development. Staff notes that many of the following comments were also provided for the Concept Review of this project at the September 3, 2020 Planning Commission meeting and remain unaddressed.

Although the request does not include a proposed Future Land Use Map amendment, one is required since the proposed RS-8 zoning is not compatible with the existing *Rural* Future Land Use designation.

The Commercial-Rural zoning designation requires large parcel sizes and limits the amount of lot coverage to allow for septic systems; however, with a proposed force sanitary sewer main and urban-type “Village Center”, a more compatible zoning designation is needed. A significant number of waivers have been requested for development of a greenfield site. The numerous waivers being requested are an indication that a more intense Commercial zoning district would better align with the proposed lot coverage, uses, setbacks, density, etc. Staff notes that Figure 5 in the application report identifies RS zone-type developments in the greenbelt, all but one of which predates the 2000 establishment of the greenbelt, and the singular exception is a conservation subdivision with a half-acre per unit density (Martin Meadows).

Similarly, the proposed RS-8 zoning is not compatible with the proposed mixed-density residential development. An RM-1 designation would allow for single-family, duplex and multifamily structures. The density and design standards for multifamily development do not apply to RS zones. However, Staff notes that, since the only zoning districts and Future Land Use designations in the area are industrial, rural and government, any other type of zoning and FLU designations would be isolated and unlike any other classifications in this part of Athens-Clarke County.

As noted by the ACC Traffic Engineer, a traffic impact analysis (TIA) is required for this development. The application report denotes an expected 8,000 trips per day generated at full build-out of the development. It can be anticipated that much of these generated trips will exit left onto Old Elberton Road, passing by the school, in order to take Spring Valley Road into town or Voyles Road to reach US 72 (Hull Road). This would effectively place an additional 800 peak hour trips into a single four-way intersection during peak school traffic.

The Transportation Corridor Concept Map (TCC) shows a planned minor collector running through the middle of the property. This corridor could either be incorporated into the proposed development street network or set aside as temporary open space reserved for future construction.

ACC Public Utilities needs to pre approve the proposed sanitary sewer extension on Old Elberton Road, while the Mayor and Commission will need to approve the proposed lift station and force main.

While generally the Staff does not support this request in its current form based on the information noted above, additional Staff comments are as follows:

1. A vicinity map is required for the next submittal
2. A more detailed parking plan will be needed; specifically, showing the required ADA parking spaces.

3. A breakdown of the number of bedrooms in each dwelling unit is needed for Staff to confirm parking compliance.
4. A Development of Regional Impact analysis by the Northeast Georgia Regional Commission is required prior to a Master Plan recommendation by the Planning Commission.

II. PLANNING COMMISSION RECOMMENDATIONS - Pending

III. CURRENT STATUS

The Planning Commission is scheduled to consider the request at their regular meeting on November 9, 2020. At that time, the Planning Commission will review the submitted application and provide comments only.

REPORT FOR: Old Elberton Road

Zoning Criteria for Type I Applications

1. The Future Development Map and its intended outcome, the general plans for the physical development of Athens-Clarke County, and any master plan or portion thereof adopted by the Mayor and Commission.
2. The proposed rezoning will not adversely affect the balance of land uses in Athens-Clarke County.
3. Public facility elements of the Comprehensive Plan and how the proposed change will affect the provision of the services anticipated in the plan.
4. The proposed use meets all objective criteria set forth for that use provided in the zoning ordinance and conforms to the purpose and intent of the Comprehensive Plan and all its elements.
5. The existing land use pattern surrounding the property in issue.
6. The possible creation of an isolated district unrelated to adjacent and nearby districts.
7. The population density pattern and possible increase or over-taxing of the load on public facilities including, but not limited to, schools, utilities, and streets.
8. The cost of the Unified Government and other governmental entities in providing, improving, increasing or maintaining public utilities, schools, streets and other public safety measures.
9. The possible impact on the environment, including but not limited to, drainage, soil erosion and sedimentation, flooding, air quality and water quantity.
10. Whether the proposed zoning amendment will be a deterrent to the value or improvement of development of adjacent property in accordance with existing regulations.
11. Whether there are substantial reasons why the property cannot be used in accordance with existing zoning; provided, however, evidence that the economic value of the property, as currently zoned, is less than its economic value if rezoned as requested will not alone constitute a significant detriment.
12. The aesthetic effect of existing and future use of the property as it relates to the surrounding area.
13. Whether there are other existing or changing conditions affecting the use and development of the property which give supporting grounds for either approval or disapproval of the zoning proposal.



Zoning Map of Athens-Clarke County

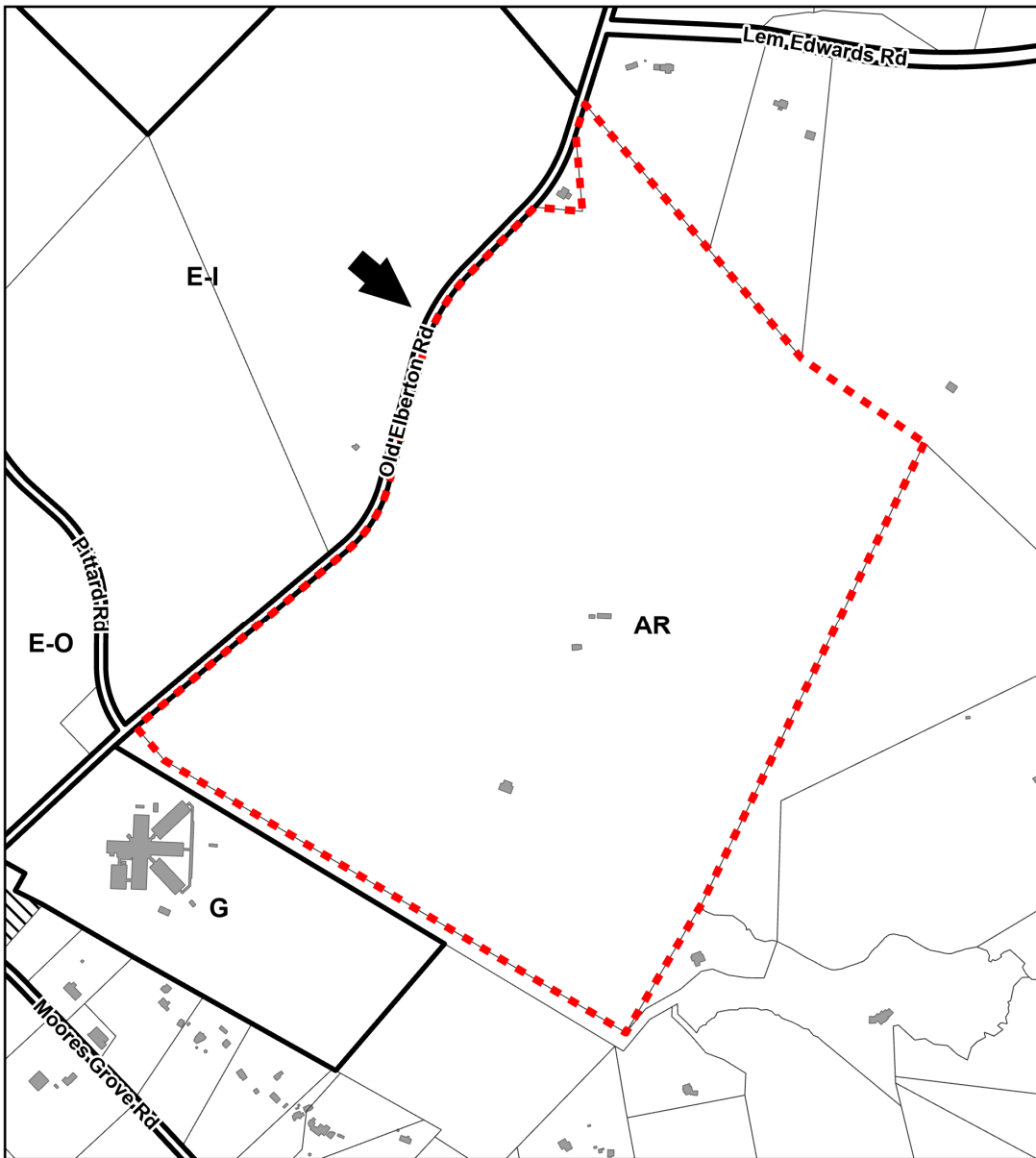

LEGEND

- Site Location
- ACC Zoning
- AR** Agricultural Residential
(1 unit per 10 acre density)
- RS-40** Single Family Residential
(40,000 sq. ft. min. lot area)
- RS-25** Single Family Residential
(25,000 sq. ft. min. lot area)
- RS-15** Single Family Residential
(15,000 sq. ft. min. lot area)
- RS-8** Single Family Residential
(8,000 sq. ft. min. lot area)
- RS-5** Single Family Residential
(5,000 sq. ft. min. lot area)
- RM-1** Mixed Density Residential
(16 multi-family units per acre)
- RM-2** Mixed Density Residential
(24 multi-family units per acre)
- RM-3** Mixed Density Residential
(50 multi-family units per acre)
- G** Government
- P** Parks
- C-G** Commercial General
- C-D** Commercial Downtown
- C-N** Commercial Neighborhood
- C-O** Commercial Office
- C-R** Commercial Rural
- E-O** Employment-Office
- E-I** Employment-Industrial
- I** Industrial
- IN** Institutional
- Downtown Design Area
 - (DHD)** Downtown Historic District
 - (WD)** West Downtown
 - (ED)** East Downtown
 - (DS)** Dougherty Street
 - (RIV)** River
 - (WE)** West End
- RM-LTD, Mixed Density Residential Limited Overlay
- GSRC, Gaines School Road Corridor Special District Overlay
- MAC, Milledge Avenue Corridor Special District Overlay
- WBS, West Broad Street Special District Overlay
- A, Airport Overlay Zone
 - AZ1** Precision Approach Zone
 - AZ2** Larger than Utility Runway Nonprecision Approach Zone
 - AZ3** Utility Runway Nonprecision Approach Zone
 - TZ** Transitional Zone
 - RPZ** Runway Protection Zone
 - PSZ** Primary Surface Zone
- PD, Planned Development
- CSPD, Conservation Subdivision Planned Development
- Zoning with Condition
- Conditional Use
- Special Use
- Local Historic Landmark
- Local Historic District Boundary

Parcel boundaries of the site are determined by legal description.
The parcels shown on this map are to be used only as a guide.



1200120
 Feet

Type I PD-2020-10-2876 PRELIMINARY PLANNED DEVELOPMENT OLD ELBERTON ROAD Johnny Tumlin FAE Clarke, LLC		FROM: TO: AR C-R/RS-8 (PD)
TAX PARCEL #	PLANNING COMMISSION MEETING DATE	ATHENS-CLARKE COUNTY COMMISSION MEETING DATE
p/o 273 001	November 9, 2020	NA

**STAFF REPORT
PRELIMINARY PLANNED DEVELOPMENT
CASE NUMBER PD-2020-10-2863
175 TRACY STREET
NOVEMBER 9, 2020**

GENERAL INFORMATION AND PROPOSED DEVELOPMENT

I. THE REQUEST

APPLICANT Brett Nave / Studio BNA, Inc.
OWNER 635 Barber Street, LLC
ZONING REQUEST..... From E-I (Employment-Industrial) to E-O (PD)
(Employment-Office, Planned Development)
TYPE OF REQUEST Type II
LOCATION..... 175 Tracy Street
COUNTY COMMISSION DISTRICT 3
SIZE OF REZONING AREA 7.20 acres
PRESENT USE Undeveloped
PROPOSED USE Multifamily residential / Commercial / Industrial
TAX MAP NUMBER 114B 002B
ADJACENT USES AND ZONING..... (N) Argos Cement Manufacturing / E-I; Chase
Street Warehouses / E-O
..... (E) Single-family dwellings / E-I, Special Use in C-
G;
..... (S) Active Climbing Gym / E-O; Buvez Café, other
small retail spaces / E-I; Single-family dwellings /
RS-8
..... (W) Athens Plumbing and other similar commercial
uses / C-N
STAFF RECOMMENDATIONS: **Receive with comments**
PLANNING COMM. RECOMMENDATION **Pending**

II. PURPOSE

The purpose of this request is to rezone a 7.20-acre parcel currently zoned E-I (Employment-Industrial) to E-O (PD) (Employment-Office, Planned Development) in order to create a mixed-use development which combines elements of commercial, industrial, and residential space. A planned development is being requested due to several requested waivers of required standards to provide design flexibility. A planned development includes a binding application report, site plan, and architectural elevations as a guarantee to the community that what is proposed will be constructed.

III. EXISTING CONDITIONS OF SUBJECT PROPERTY AND VICINITY

The 7.20-acre subject parcel at 175 Tracy Street is located at the intersection of Tracy Street and Barber Street, with the southwestern border of the parcel formed by the Seaboard Coastline Railroad right-of-

way. The property is currently zoned as E-I (Employment-Industrial). It is currently undeveloped and, per the Applicant's report, has remained undeveloped for the past two decades.

To the north, across Tracy Street, are properties zoned E-I (Employment-Industrial) and E-O (Employment-Office), which contain Argos Cement Manufacturing and the Chase Street Warehouses, respectively; to the east are several single-family dwellings located on C-G (Commercial-General) zoned properties (as well as one single-family dwelling located at 697 Barber Street, which is zoned E-I and surrounded on three sides by the subject property); to the south is Active Climbing Gym (zoned E-O), and more single-family dwellings located on RS-8 parcels; to the southwest are commercial properties located within a C-N (Commercial-Neighborhood) zoning district. The subject parcel is not located within a local or National Register historic district.

IV. PROPOSED DEVELOPMENT

The proposal is for the construction of a mixed-use development, which will contain elements of commercial, residential, and industrial use. Among the six proposed buildings will be 5,141 square feet of commercial space, 108 bedrooms (a mix of 66 one-bedroom and 21 two-bedroom units), and one building designated entirely for industrial use (comprised of 3,380 square feet). Also proposed is an amenity building with a series of kiosks to provide leasable start-up commercial space.

Pedestrian amenities include sidewalks, a mulched path throughout the site, and the construction of a 10-foot multi-use path built according to Athens Greenway standards.

The proposed development also proposes nine of the one-bedroom units as affordable workforce housing serving residents within the 80%-120% AMI range (area median income). Staff notes that Athens-Clarke County does not have a regulatory mechanism for the provision, enforcement, or maintenance of the affordability for these units.

Scaled architectural elevations have been submitted with this preliminary review. The proposed architecture for the site is contextually compatible with the industrial area, utilizing brick exteriors with warehouse-like detailing and steel replica gilded windows.

COMPATIBILITY WITH COMPREHENSIVE PLAN

I. COMPATIBILITY WITH FUTURE LAND USE MAP

The Future Land Use Map indicates that the subject parcel has an *Employment Center* designation, which would remain as part of this request; the designation is described as follows:

Employment Center: These are areas of industry, office, research parks, and flex-space mixed uses. Two types of employment areas are distinguished in the land-use classifications for the specific properties. The first type is large-scale employment areas, which include large industrial areas, manufacturing, office parks, and research centers. Housing is incompatible with these areas. As these areas are generally not visible from the main corridors of the community, design standards should only be employed within areas that are visible from main corridors and for buffering adjacent residential areas. The second type of employment area is smaller in scale and is appropriate to be in close proximity to a neighborhood area. Design standards regulating building placement, landscaping, and buffering should apply. Housing and small amounts of retail may be compatible in some areas.

II. COMPATIBILITY WITH VISION STATEMENTS, ISSUES AND OPPORTUNITIES & POLICIES

Some of the relevant Comprehensive Plan vision statements, strategies, and policies:

- [Provide] housing options that reflect the diversity and meet the needs of the community, including housing for families and a diverse workforce. These are quality options with a variety of types, prices, and locations.
- Ensure that mixed-use development truly provides multiple uses amongst varying architecture and structure size.

COMPATIBILITY WITH ZONING MAP AND ORDINANCE STANDARDS

I. COMPATIBILITY WITH ZONING MAP

The purpose of this request is to designate a Planned Development at 175 Tracy Street, currently zoned E-I (Employment-Industrial), into E-O (PD) (Employment-Office, Planned Development) in order to construct a new mixed-use development with elements of commercial, residential, and industrial uses. However, Staff has concerns with the requested residential portion (85.6% of the gross square footage), as this would create an incompatibility with the proposed underlying zoning district of E-O (which allows a maximum of 20% residential) and its purpose of office and manufacturing as expressed in Sec. 9-11-1.

II. COMPATIBILITY WITH ORDINANCE STANDARDS

All exemptions to the zoning and development standards must be identified in the application prior to approval of a binding proposal since the development will otherwise be expected to adhere to the ordinance standards. The following waivers have been requested:

1. *Waiver from Section 9-11-14, to allow for a reduction in the minimum front yard setback*
A waiver has been requested to decrease the minimum front yard setback from 10' to 2' in order to dedicate the appropriate amount of right-of-way needed to contain the proposed public sidewalk along Tracy Street - this waiver is specifically for buildings A, B, and D, where protected environmental areas limit the developable area.
2. *Waiver from Section 9-11-2, to allow for mixed-use development*
A waiver has been requested to allow for dwellings above businesses as a permitted use within the use chart for developments within E-O zoning districts, in order to construct a vertically mixed-use development.
3. *Waiver from Section 9-11-2, to increase the percentage of residential square footage above the maximum 20% allowed within E-O zoning districts*
The proposed total gross square footage for the development is 78,808 square feet, of which residential components constitute 85.6% (67,494 SF).

4. *Waiver from Section 9-25-8-C-6C and 9-25-8-D-2E, to forego required landscape buffers*

The Applicant notes that the waiver being requested for landscape buffers will only apply to Buildings A and B, where the developable areas are limited by environmental areas. Landscape areas of 10 feet shall be provided for all other buildings adjacent to streets.

Staff review has discovered other aspects of the project that either need amendment or the request of additional waivers. The following **technical standards** should be addressed with the Master Planned Development submittal:

1. The number of dwelling units needs to be clarified since the site plan and the application report denote 66 one-bedroom units, while the provided floorplans depict only 64. The number of units, their locations, and their sizes need to be finalized in order to clarify the resulting density and parking calculations and solidify the associated waiver requests.
2. Bicycle parking needs to be depicted on the site plan.
3. The stream on the southwestern corner of the parcel is labeled as a mulched path; this labeling should be corrected accordingly.
4. The lot coverage calculations denote that one acre of lot coverage is existing; however, the site plan depicting the existing conditions does not show any lot coverage.
5. Per 9-25-8-C-8(a): building façades cannot be more than 100' in length without a change in façade; the proposed buildings either need to meet this standard or a waiver requested.
6. Several of the one-bedroom units appear to have a square footage less than 500 SF, which only requires 1 parking space (rather than the 1.5 parking spaces denoted within the parking calculations); the parking calculations should be revised accordingly.

Staff strongly recommends that the Master Planned Development also address the following **site design issues**:

1. Staff has various parking concerns. Building A will have only 5 on-site parking spaces for over 5,000 square feet of commercial space and 8 one-bedroom units (Staff also notes that Building A is the only building with commercial space). On-street spaces are proposed along Tracy Street, which cannot be dedicated to the proposed development, and vehicles associated with the Chase Street Warehouses already park along Tracy Street (even with the absence of formal parking spaces). The one per 300 sf parking calculation provided by the applicant for the commercial space are for retail, and would not apply to a restaurant use, which has a higher parking calculation. Building B also seems to have no direct parking.
2. Tree plantings are proposed within the delineated wetland. Ornamental plantings are often ecologically inappropriate for wetland ecosystems and wetland biodiversity often never return to previous levels, even with intensive restoration efforts.
3. Clarification regarding intended uses for the start-up space, as well as the industrial and commercial space, need to be addressed in order to justify the one parking space per 350 sf calculation, which only applies to a medical office.
4. Without information regarding specific intended uses for the Commercial, Industrial, and start-up spaces, the default use standards will be those associated with the E-O zoning district.

EFFECT ON COMMUNITY

I. BALANCE OF LAND USES IN ATHENS-CLARKE COUNTY

The proposed planned development would increase the amount of residential, commercial, and industrial uses within a growing portion of Athens-Clarke County. While the increase is not insignificant, the parcel could serve as a transition between the existing Chase Street Warehouses and industrial uses along Tracy Street and the single-family dwellings located within the Boulevard Historic Neighborhood.

Other properties in the immediate vicinity have E-I (Employment-Industrial) and E-O (Employment-Office) zoning. Staff has significant concerns with a potential negative deterrence on additional investment in the development or redevelopment for nearby industrial properties due to perceived negative impacts (noise, odors, vibration, etc.) on the future residents.

Athens-Clarke County has recently seen a significant increase of multifamily developments. In the past two years over 8,500 multifamily bedrooms have been permitted for construction, are being processed through the plans review process, or are under consideration by the Planning Commission or Mayor and Commission. Taken into consideration with the other recent requests, the accumulative effect creates a significant impact on the balance of land uses in Athens-Clarke County.

II. POPULATION

The resident population of the immediate region will increase by 108 bedrooms, which is not insignificant given that the residential aspect of the surrounding area is largely limited to single-family dwellings and smaller residential areas.

III. ENVIRONMENT

The Athens-Clarke County Environmental Areas Map shows riparian buffers on this parcel since there is a piped stream which daylight on the northeastern and southwestern portions of the site. A portion of the parcel also lies within the 100-Year Floodplain, which is shown on the site plan, but its delineation does not match that of ACC GIS. The site plan also shows a wetland which does not appear on ACC GIS, and the application report denotes that wetland consultants will coordinate with USACE (U.S. Army Corps of Engineers) to determine whether it is a jurisdictional protected wetland.

The site appears to be filled with invasive vegetative species, such as kudzu (*Pueraria lobata*), Chinese privet (*Ligustrum sinense*), and other species associated with disturbed urban habitats.

The Athens-Clarke County Arborist has reviewed the provided Tree Management Plan (TMP) and has the following comments:

- *The protected environmental area on the eastern side of the project limits tree and vegetation removal. Further information is needed to show compliance with ACC Code and Environmental Protection Division standards. The TMP should also indicate if forest regeneration requirements in ACC Code Sec. 8-7-19(f) will be used in that location in order to count toward planted canopy. If that area is to be counted for the overall figure, then 1,600 sq. ft. for the pecan tree needs to be removed from the total as it exists in that same space.*

- *Plans show a conserved canopy of 17.78%, which is above the required 15% required for the E-O zone. For the area inside the protected environmental areas on the western side of the property to be counted, it must be cleared of kudzu, Chinese privet, and other invasive species, with the removal done in compliance with the Environmental Areas ordinance.*
- *Portions of the internal street network show small canopy trees where large canopy trees are required.*
- *The provided artistic renderings show more trees than indicated on the Tree Management Plan.*

IV. TRAFFIC, TRANSPORTATION, & TRANSIT

Currently, there are no sidewalks along the two street frontages of the parcel. The proposed site plan displays new sidewalks on both the Tracy and Barber Street frontages, as well as including a 10-foot multiuse path through the center of the development (in line with a future trail shown on the Athens Greenway Network Master Plan). The multiuse path will be held under a public easement in order to ensure future access. The site is currently served by Athens Transit Route 8.

The Athens-Clarke County Department of Transportation and Public Works has reviewed the proposal and does not have any transportation-related comments at this time.

V. GRADING AND DRAINAGE

The existing site does not contain any stormwater management facilities. The application report indicates that runoff reduction volume (RRv) will be prioritized with infiltration practices strategically located throughout the site to promote infiltration and reduce quantity of post-development site discharge (e.g. permeable pavement, bioretention areas, landscape plantings, and gravel infiltration). Underground detention is proposed to handle increased volume from large storm events. The site will meet all stormwater management requirements per the ACC Code and all applicable regulations. The exact configuration and details of the stormwater management system will be determined at the time of permitting.

The Athens-Clarke County Department of Transportation and Public Works has reviewed the proposal and does not have any grading- or drainage-related comments at this time.

VI. WATER AND SEWER AVAILABILITY

ACC water and sanitary sewer are available to serve the proposed development.

VII. FIRE PROTECTION

The ACC Fire Marshall has reviewed the plans and denotes that ACCFES can provide fire protection without any fire services being negatively affected or additional cost for fire equipment or personnel. Additional fire hydrants are needed. Fire apparatus can access the project. A turnaround is not needed. Buildings must be sprinkled and alarmed.

RECOMMENDATIONS

I. STAFF RECOMMENDATION - Receive with comments

The purpose of this request is to designate a Planned Development at 175 Tracy Street, currently zoned E-I (Employment-Industrial), into E-O (PD) (Employment-Office, Planned Development) in order to construct a new mixed-use development with elements of commercial, residential, and industrial uses.

The purpose of the preliminary planned development review is to provide an opportunity for the Planning Commission to comment on the project prior to the preparation of a master development plan. Any comments by the Planning Commission are for the benefit of the applicant in drafting the master development plan and shall not be binding.

Staff has concerns with the compatibility of the underlying zoning and future land use categories, as well as portions of the site design. The transition from E-I to E-O is not unheard of, as the neighboring parcel located at 665 Barber Street was rezoned similarly in 2012. However, the E-O zoning has a limit of 20% of the total floor area being used for residential uses, and the current waiver is requesting 85.6%. As previously noted, the expressed purpose of the E-O zoning per Sec. 9-11-1 is for office and manufacturing uses.

Other properties in the immediate vicinity have E-I (Employment-Industrial) and E-O (Employment-Office) zoning. Staff has significant concerns with a potential negative deterrence on additional investment in the development or redevelopment for nearby industrial properties due to perceived negative impacts (noise, odors, vibration, etc.) on the future residents.

Athens-Clarke County has recently seen a significant increase of multifamily developments. In the past two years over 8,500 multifamily bedrooms have been permitted for construction, are being processed through the plans review process, or are under consideration by the Planning Commission or Mayor and Commission. Taken into consideration with the other recent requests, the accumulative effect creates a significant impact on the balance of land uses in Athens-Clarke County.

The following are several technical standards and site design issues that the Applicant should address prior to the Master Planned Development Submittal:

1. The number of dwelling units needs to be clarified since the site plan and the application report denote 66 one-bedroom units, while the provided floorplans depict only 64. The number of units, their locations, and their sizes need to be finalized in order to clarify the resulting density and parking calculations and solidify the associated waiver requests.
2. Bicycle parking needs to be depicted on the site plan.
3. The stream on the southwestern corner of the parcel is labeled as a mulched path; this labeling should be corrected accordingly.
4. The lot coverage calculations denote that one acre of lot coverage is existing; however, the site plan depicting the existing conditions does not show any lot coverage.
5. Per 9-25-8-C-8(a): building façades cannot be more than 100' in length without a change in façade; the proposed buildings either need to meet this standard or a waiver requested.
6. Several of the one-bedroom units appear to have a square footage less than 500 SF, which only requires 1 parking space (rather than the 1.5 parking spaces denoted within the parking calculations); the parking calculations should be revised accordingly.

Staff strongly recommends that the Master Planned Development also address the following **site design issues**:

1. Staff has various parking concerns. Building A will have only 5 on-site parking spaces for over 5,000 square feet of commercial space and 8 one-bedroom units (Staff also notes that Building A is the only building with commercial space). On-street spaces are proposed along Tracy Street, which cannot be dedicated to the proposed development, and vehicles associated with the Chase Street Warehouses already park along Tracy Street (even with the absence of formal parking spaces). The one per 300 sf parking calculation provided by the applicant for the commercial space are for retail, and would not apply to a restaurant use, which has a higher parking calculation. Building B also seems to have no direct parking.
2. Tree plantings are proposed within the delineated wetland. Ornamental plantings are often ecologically inappropriate for wetland ecosystems and wetland biodiversity often never return to previous levels, even with intensive restoration efforts.
3. Clarification regarding intended uses for the start-up space, as well as the industrial and commercial space, need to be addressed in order to justify the one parking space per 350 sf calculation, which only applies to a medical office.
4. Without information regarding specific intended uses for the Commercial, Industrial, and start-up spaces, the default use standards will be those associated with the E-O zoning district.

II. PLANNING COMMISSION RECOMMENDATION – Pending

III. CURRENT STATUS

The Planning Commission is scheduled to consider the request at their regular meeting on November 9, 2020. At that time, the Planning Commission will review the submitted application and consider a recommendation to “Receive the Preliminary Plan with Comments.” Submittal of a Master Planned Development report and plan will follow a subsequent review cycle schedule.

REPORT FOR: 175 Tracy Street

Reviewed	Not Applicable	<u>Zoning Criteria for Type II Applications</u>
X		1. The proposed rezoning conforms to the future development map, the general plans for the physical development of Athens-Clarke County, and any master plan or portion thereof adopted by the Mayor and Commission.
	X	2. The proposed special use meets all objective criteria set forth for that use provided in the zoning ordinance and conforms to the purpose and intent of the comprehensive plan and all its elements.
X		3. Public services, which include physical facilities and staff capacity, exist sufficient to service the proposed rezoning.
X		4. The proposed rezoning will not adversely affect the balance of land uses in Athens-Clarke County.
X		5. Existing land use pattern surrounding the property in issue
X		6. Possible creation of an isolated district unrelated to adjacent and nearby districts
X		7. Population density pattern and possible increase or over-taxing of the load on public facilities including, but not limited to, schools, utilities and streets
X		8. The cost of the Unified Government and other governmental entities in providing, improving, increasing or maintaining public utilities, schools, streets and other public safety measures
X		9. The possible impact on the environment, including but not limited to, drainage, soil erosion and sedimentation, flooding, air quality and water quantity
X		10. Whether the proposed zoning amendment will be a deterrent to the value or improvement of development of adjacent property in accordance with existing regulations
X		11. Whether there are substantial reasons why the property cannot be used in accordance with existing zoning; provided, however, evidence that the economic value of the property, as currently zoned, is less than its economic value if rezoned as requested will not alone constitute a significant detriment
X		12. The aesthetic effect of existing and future use of the property as it relates to the surrounding area
X		13. Whether there are other existing or changing conditions affecting the use and development of the property which give supporting grounds for either approval or disapproval of the zoning proposal



Zoning Map of Athens-Clarke County

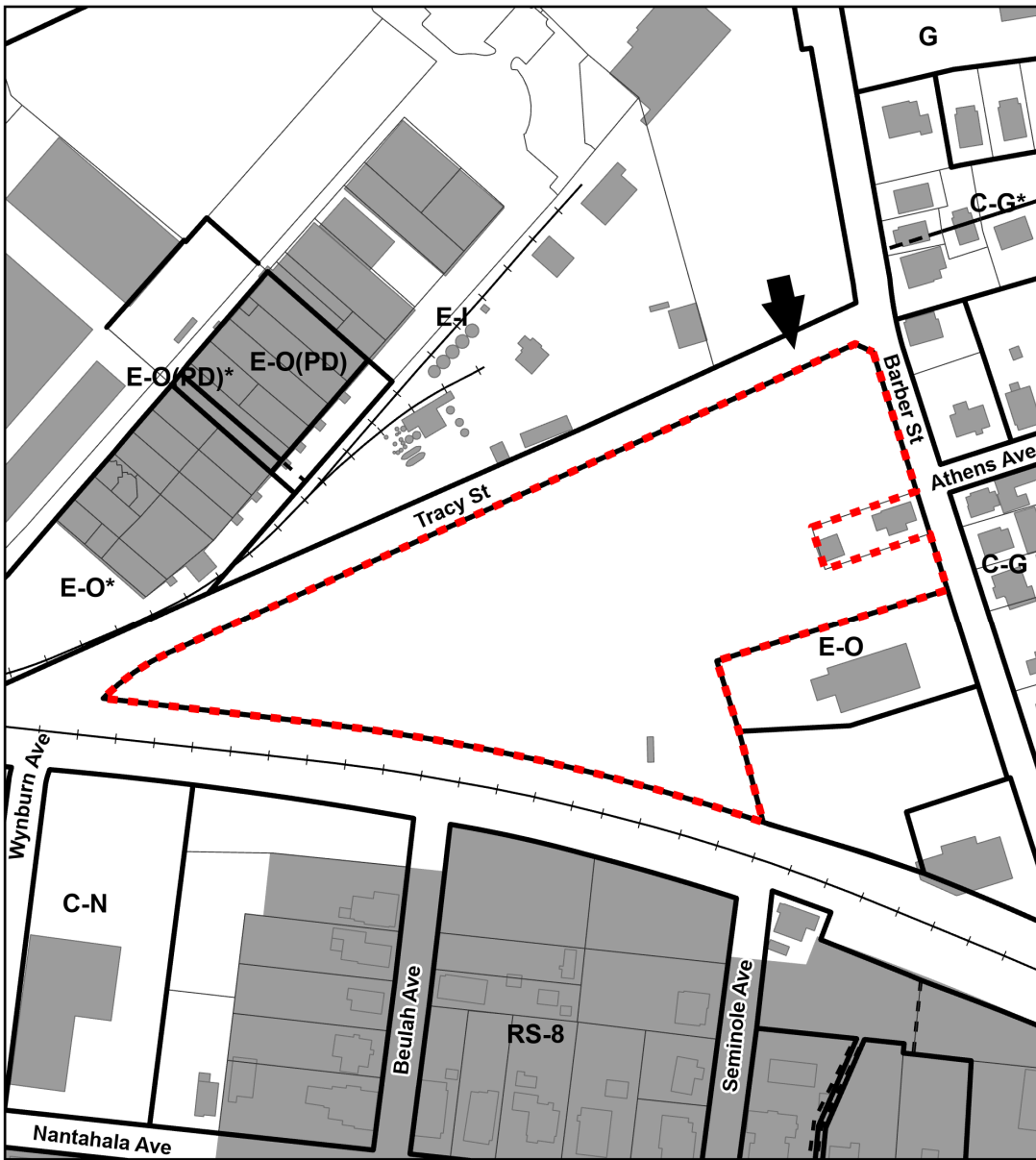

LEGEND

- Site Location
- ACC Zoning
- AR** Agricultural Residential
(1 unit per 10 acre density)
- RS-40** Single Family Residential
(40,000 sq. ft. min. lot area)
- RS-25** Single Family Residential
(25,000 sq. ft. min. lot area)
- RS-15** Single Family Residential
(15,000 sq. ft. min. lot area)
- RS-8** Single Family Residential
(8,000 sq. ft. min. lot area)
- RS-5** Single Family Residential
(5,000 sq. ft. min. lot area)
- RM-1** Mixed Density Residential
(16 multi-family units per acre)
- RM-2** Mixed Density Residential
(24 multi-family units per acre)
- RM-3** Mixed Density Residential
(50 multi-family units per acre)
- G** Government
- P** Parks
- C-G** Commercial General
- C-D** Commercial Downtown
- C-N** Commercial Neighborhood
- C-O** Commercial Office
- C-R** Commercial Rural
- E-O** Employment-Office
- E-I** Employment-Industrial
- I** Industrial
- IN** Institutional
- Downtown Design Area
 - (DHD)** Downtown Historic District
 - (WD)** West Downtown
 - (ED)** East Downtown
 - (DS)** Dougherty Street
 - (RIV)** River
 - (WE)** West End
- RM-LTD, Mixed Density Residential Limited Overlay
- GSRC, Gaines School Road Corridor Special District Overlay
- MAC, Milledge Avenue Corridor Special District Overlay
- WBS, West Broad Street Special District Overlay
- A, Airport Overlay Zone
 - AZ1** Precision Approach Zone
 - AZ2** Larger than Utility Runway Nonprecision Approach Zone
 - AZ3** Utility Runway Nonprecision Approach Zone
 - TZ** Transitional Zone
 - RPZ** Runway Protection Zone
 - PSZ** Primary Surface Zone
- PD, Planned Development
- CSPD, Conservation Subdivision Planned Development
- Zoning with Condition
- Conditional Use
- Special Use
- Local Historic Landmark
- Local Historic District Boundary

Parcel boundaries of the site are determined by legal description.
The parcels shown on this map are to be used only as a guide.

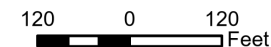

Type II PD-2020-10-2863 PRELIMINARY PLANNED DEVELOPMENT 175 TRACY STREET Brett Nave / Studio BNA, Inc. 635 Barber Street, LLC		FROM: TO: E - I E - O (PD)
TAX PARCEL #	PLANNING COMMISSION MEETING DATE	ATHENS-CLARKE COUNTY COMMISSION MEETING DATE
114B 002B	November 9, 2020	TBD

**STAFF REPORT
PRELIMINARY PLANNED DEVELOPMENT
CASE NUMBER PD-2020-10-2875
100 NEWTON BRIDGE RD
November 9, 2020**

GENERAL INFORMATION AND PROPOSED DEVELOPMENT

I. THE REQUEST

APPLICANT Ed Lane, Smith Planning Group
 OWNER Westclox Rocks LLC
 ZONING REQUEST..... From I to E-O (PD)
 TYPE OF REQUEST Type II
 LOCATION..... 100 Newton Bridge Rd
 COUNTY COMMISSION DISTRICT..... 3
 SIZE OF REZONING AREA 35.12 acres
 PRESENT USE Bottling Plant / Office / Vacant space
 PROPOSED USES..... Mixed-use: Retail, Residential, Industrial, Office &
 Hotel
 TAX MAP NUMBER 112 003
 ADJACENT USES AND ZONING..... (N) Power Partners/I
 (S) Dairy Pak Rd; East Georgia Communications/I
 (E) Georgia Power/I
 (W) Newton Bridge Rd; Terrapin Brewery, Credit
 Union, Southeastern Color Lithographers, Girl
 Scouts NE GA Council/I; ACC Fleet
 Management/G; undeveloped/C-G
 STAFF RECOMMENDATION..... **Receive with comments**
 PLANNING COMMISSION **Pending**

II. PURPOSE

The purpose of this request is to rezone one parcel currently zoned I (Industrial) to E-O (PD) (Employment Office, Planned Development) to construct a mixed-use residential, retail, industrial, office and hotel development on a 35.12-acre site. A planned development is being requested due to several requested waivers of required standards to provide design flexibility. A planned development includes a binding application report, site plan, and architectural elevations as a guarantee to the community that what is proposed would be constructed. The request does not require amending the Future Land Use Map designation from *Employment Center*.

III. EXISTING CONDITIONS OF SUBJECT PROPERTY AND VICINITY

The subject parcel is currently home to the former WestClox manufacturing facility, a current Terrapin Beer warehouse and Wayfair call center with some surface parking and loading docks. The building fronts Newton Bridge Road with three driveways (one closed off) and parking between the building and the road. It also has one driveway to the south off Dairy Pak Road that provides access to some parking

and the rear loading facilities. A narrow strip of the subject property extends east off the northeast corner to a railway line.

The property currently has a primary structure (separated in two earlier this year for Terrapin and Wayfair) and two outbuildings. The primary building was constructed in 1954 and an addition was built on the north end in the 1990's. The larger of the two outbuildings is a steel frame structure of approximately 7,000 square feet, while the other outbuilding has a silo form.

The facility is mostly surrounded by other industrial uses zoned I (Industrial). ACC Fleet Management is across Newton Bridge to the west and zoned G (Government). To the southwest, at the intersection of Newton Bridge Road, Barber Street, Dairy Pak Road and Chase Street, lies a vacant parcel zoned C-G (Commercial-General).

IV. PROPOSED DEVELOPMENT

The proposal is to rezone the site to E-O (PD) (Employment-Office, Planned Development) for the construction of a hotel, residential, retail, industrial and office mixed-use development. The application report indicates the intent to renovate the site by opening up the main building, adding pedestrian improvements, new surface parking and eventually a residential component. The proposal is for flexible space accommodating non-manufacturing uses, while keeping manufacturing to the north (existing) and rear. The remainder of the older portion of the primary structure will have a pedestrian network with professional services or office and retail space. Future residential space is planned in new structures along Newton Bridge Road and for a separate hotel building along the southern end of the property. An outdoor plaza or event space is planned between the main building and Newton Bridge Road, which could be used for events or smaller performances. The intent is to maintain an industrial aesthetic, open up space for flow and incorporate current standards for parking and landscaping.

The 1990's addition has been converted by Terrapin Beer Company for a new packaging and shipping facility. The southern portion of that addition has been renovated for Wayfair. The design architecturally matches existing structures on the property and in the vicinity. The planned residences consist of 100 two-bedroom dwellings and 100 one-bedroom dwellings.

The project will have several surface parking lots that connect throughout the development. Drives will interconnect to the Power Partners property to the north to allow ingress and egress for larger trucks serving the Terrapin storage facility.

The development is seeking to provide multiple options for transportation. The property is located along an Athens Transit route and the project provides pedestrians and bicycle connections. The long-range plan is to connect to a future ACC greenway planned to follow the western side of the North Oconee River. Also, the Athens in Motion plan has a future shared use path along Barber Street, which this project intends to extend and connect with its interior bike/pedestrian infrastructure.

COMPATIBILITY WITH COMPREHENSIVE PLAN

I. COMPATIBILITY WITH FUTURE LAND USE MAP

The Future Land Use Map indicates that the subject parcel currently has an *Employment Center* designation, which is described as follows:

These are areas of industry, office, research parks, and flex-space mixed uses. Two types of employment areas are distinguished in the land-use classifications for the specific properties. The first type is large-scale employment areas, which include large industrial areas, manufacturing, office parks, and research centers. Housing is incompatible with these areas. As these areas are generally not visible from the main corridors of the community, design standards should only be employed within areas that are visible from main corridors and for buffering adjacent residential areas. The second type of employment area is smaller in scale and is appropriate to be in close proximity to a neighborhood area. Design standards regulating building placement, landscaping, and buffering should apply. Housing and small amounts of retail may be compatible in some areas.

The proposed E-O zoning is compatible with the existing *Employment Center* designation per the Compatibility Matrix in Chapter 9-4.

II. COMPATIBILITY WITH VISION STATEMENTS, ISSUES AND OPPORTUNITIES & POLICIES

Some of the relevant Comprehensive Plan vision statements, opportunities, and policies:

- Policy: Encourage the appropriate development of Research Parks, Business Parks and/or Incubation Parks.
- Opportunity: Public Open Space creation and tree canopy preservation will be a major priority within our neighborhoods, along our streets, parking lots and within commercial and industrial developments.
- Policy: A mix of housing types, including workforce and life-cycle housing, will be encouraged.
- Policy: Athens-Clarke County will continue to encourage redevelopment and infill development in preference to Greenfield development.
- Policy: Athens-Clarke County will support residential and non-residential in-fill development that positively contributes to the character of existing neighborhoods and meets the goal of providing housing and services close to existing infrastructure.
- Opportunity: Sustainable development should achieve a balance that satisfies the community's housing, recreational, educational, commercial, and industrial needs.

COMPATIBILITY WITH ZONING MAP AND ORDINANCE STANDARDS

I. COMPATIBILITY WITH ZONING MAP

The purpose of this request is to rezone 100 Newton Bridge Road from I (Industrial) to E-O (PD) (Employment Office, Planned Development) for a commercial, entertainment, residential and industrial development. The area immediately surrounding the subject parcels is comprised of three zoning categories - I (Industrial), G (Government) and C-G (Commercial-General). The proposal is to introduce an E-O zoning district into the area. The result would be a slightly less intensive industrial zoning district along Newton Bridge Road that allows for residential use and flexibility. Otherwise, the proposed zoning is similar to the adjoining districts, so Staff finds that approval would not create an isolated zoning district.

II. COMPATIBILITY WITH ORDINANCE STANDARDS

All exemptions to the zoning and development standards must be identified in the application prior to approval of a binding proposal since the development would otherwise be expected to adhere to the ordinance standards. Staff finds the plans comply with the applicable ordinance standards, except for the following six requested waivers:

1. *Waiver from Community Tree Management Section 8-7-15, conserved canopy, which specifies that the minimum conserved tree canopy in the E-O zone is 15%.*
A waiver has been requested to reduce the conserved tree canopy of the proposed mixed use, multi-structure project to 5.45% and seek alternative compliance to reach the required conserved and planted figure of 40%. The applicant would like to remove a portion of the existing canopy due to the presence of the invasive Callery Pear (*Pyrus calleryana*) and also replace existing perimeter trees with more plantings throughout the site. The ACC Arborist has provided comments on this request in the “Environment” section of this report.
2. *Waiver from Zoning and Development Regulations Sections 9-11-2(L3) Percentage of Residential space in an E-O zoned project*
The project is proposing two residential structures, which would increase the allowable amount of residential square footage from 20% to 35%.
3. *Waiver from Zoning and Development Regulations Sections 9-11-2 Allowable Uses*
A waiver has been requested to allow Light Manufacturing, Heavy Manufacturing, Food Processing, Manufacturing of Non-Odiferous Foods, Distribution Centers, Kennels, Wholesale Storage & Distribution. These uses would be contained to the north and eastern portions of the development. The waiver would also maintain the conforming use status of the existing Terrapin distribution center.
4. *Waiver from Zoning and Development Regulations Sections 9-11-2(L1) Allowable Use size restriction*
A waiver is requested to increase the allowable amount of retail and restaurant use from the maximum allowed 10,000 square feet for each use. The amount is undetermined at this time, but is planned for the additional use beyond the warehouse and residential space. Some of that space is projected to be office space, which is allowed without a size limitation in the E-O zone, but at this time, the development is not specifically demarcated beyond the above uses.
5. *Waiver from Zoning and Development Regulations Sections 9-11-2 Allowable Uses*
A waiver is requested to allow a Theater (under 1,000 seats). This request should be combined with waiver 3.
6. *Waiver from Zoning and Development Regulations Sec. 9-25-8 C. 3. Block Size*
A waiver is requested to exceed the maximum allowable block size of 3 acres for the residential component. The project proposes a block of 5.27 acres, which accommodates the two structures and their associated parking.

EFFECT ON COMMUNITY

I. BALANCE OF LAND USES IN ATHENS-CLARKE COUNTY

As compared to the existing property uses, the proposed planned development entails a decrease in possible industrial space, and an increase in residential and commercial space. Athens-Clarke County has seen a lot of multifamily development in the past few years, but this proposal would introduce an isolated mixed-use development, including 200 multifamily dwellings, in an area of predominately industrial and commercial uses. The potential of over 150,000 sf of commercial space is a significant increase in this area. The proposal contains the allowance for some of the commercial space to be industrial instead, which would align with the current property uses. The application requests this flexibility so that the market would dictate the eventual balance of uses in the proposed development; however, overall, this would be the redevelopment of a large, single-use industrial tract for a mixed-use development of commercial, industrial, residential and entertainment uses.

II. POPULATION

The resident population of the immediate area would increase with this proposal since the request includes the construction of 300 bedrooms. The proposed one- and two-bedroom apartments in an industrial area are not typical for families, so this proposal is unlikely to have many K-12 residents.

III. ENVIRONMENT

The Athens-Clarke County Environmental Areas Map does not indicate the presence of protected environmental areas within the boundaries of the proposed planned development.

A tree management plan has been submitted as part of this proposal. The Athens-Clarke County Arborist has reviewed the plan and has the following comments:

- The Tree Management Plan denotes a conserved forested area, but only counts 23 trees planted within the last year as conserved canopy. The forested area should be noted on the plans and the recently planted trees removed as conserved canopy calculations. They are not close to maturity and provide very little ecosystem service at this point. Staff can judge the waiver without those trees being counted; however, attempts should be made to first find areas for reforestation prior to utilizing individually planted trees to make up the difference for conserved canopy. Conserved and planted canopy need to exceed what is currently shown to make up for the waiver request and larger stature trees should be mixed throughout the site.
- Standard-size, two-space parking islands can support one large canopy tree or two medium canopy trees; parking peninsulas cannot support large canopy trees. Please amend the plans and adjust the canopy figures, as well as plantings, if needed.
- Raised walkways should be provided throughout the parking lot, which typically traverse through parking islands; any adjustments must correspond to proper practices on the plan and canopy figure adjustments must be reflected on the plans.
- If overhead utilities are to be relocated along Dairy Pak Road, as indicated on the plans, then large canopy street trees will be required.

- If loading docks are to be retained/utilized on the eastern side of the property, then trees should be limited in areas of ingress/egress as their lifespan is often shortened in those high traffic zones.
- Other existing trees on the site are not shown. Are they to be removed?
- Athens Clarke County is committed to tree species diversity. Staff would like to see a list of proposed species for planting and utilization of more diversity than is seen in a standard, by-right development.

The tree management plan associated with this Planned Development proposal has been reviewed for general compliance only. The plan would be binding only in regards to the waiver request, but the aforementioned comments do not preclude compliance with all other technical standards regarding the installation and maintenance of trees as provided for in the Community Tree Management Ordinance.

IV. TRAFFIC, TRANSPORTATION, & TRANSIT

Athens-Clarke County Transit serves a route through the area with bus stops along Newton Bridge Road. Further coordination with ACC Transit is needed in regards to facility upgrades to serve the proposed development.

The plan proposes a connection to the Sandy Creek Nature Center. Coordination with ACC Leisure Services is needed.

The ACC Transportation and Public Works Department has reviewed the application materials and does not have any transportation-related comments at this time.

V. GRADING AND DRAINAGE

The application report indicates that the existing stormwater detention and water quality facilities would be upgraded to a 40,000 square foot micro pool, an extended detention wet pond or other similar facility. The development is also seeking to infiltrate precipitation throughout the site with rain gardens, enhanced swales, bioslopes and grass channels.

The ACC Transportation and Public Works Department has reviewed the application materials and does not have any grading- or drainage-related comments at this time.

VI. WATER AND SEWER AVAILABILITY

The Athens-Clarke County Public Utilities Department comments that water and sanitary sewer services are available for this development.

VII. FIRE PROTECTION

The Athens-Clarke County Fire Marshal has reviewed this request and has the following comments:

1. ACCFES can provide fire protection without any services being affected or additional cost for fire equipment or personnel.
2. Additional hydrants are needed.

3. Fire apparatus can access the project. There is not enough site information provided to determine if a turnaround is needed.
4. Buildings must be sprinkled and alarmed

RECOMMENDATIONS

I. STAFF RECOMMENDATION – Receive with comments

The purpose of the planned development request is to rezone one parcel at 100 Newton Bridge Road from I (Industrial) to E-O (PD) (Employment-Office, Planned Development), and to waive several applicable ordinance standards to construct a residential, commercial, industrial and hotel development on the former WestClox property. The requested zoning is compatible with the existing *Employment Center* Future Land Use designation, which advocates a mix of industry, office and flex-space uses. The *Employment Center* designation also describes two types of appropriate development; one is large- scale office or industrial parks where residences are not appropriate, while the other is smaller in scale with limited residential use. This proposed development has qualities of both types, being large scale with residential use. Newton Bridge Road is classified as a minor arterial and the plan reflects that through plantings, landscaped space between the road and buildings, design standards and alternative transportation options.

The request would establish the only E-O zoning along Newton Bridge Road. However, the proposed zoning is similar to adjoining industrial and commercial districts, so Staff finds that approval would not create an isolated zoning district.

The proposed development would attract visitors to a destination site in an area with predominantly industrial and pass-through traffic, so it has the potential to change the dynamic of the area. Staff sees the primary issue as the introduction of residential uses in the midst of the industrial area. Adequate separation of uses and agreements on hours of activity may help ameliorate any conflict between residents, the existing nearby industrial uses, and the proposed entertainment activities. Another concern is whether the proposed residential use would deter further investment in the development or redevelopment of nearby industrial properties. Heavy industrial use category should be removed from the allowable use waiver request as this development seeks to mix low-intensity commercial, residential and event space into one project.

The purpose of the preliminary planned development review is to provide an opportunity for the Planning Commission to comment on the project prior to the preparation of the master development plan. Any comments by the Planning Commission are for the benefit of the applicant in drafting the master development plan and shall not be binding. Staff may have additional comments on this proposal when additional or revised information has been provided for further review.

The following issues should be addressed with the master plan submittal:

1. More specific information should be provided for the proposed uses and their maximum square footages.
2. More information should be provided on the proposed phasing of the multifamily dwellings. It is Staff opinion that the multifamily development should follow commercial development.
3. Remove Heavy Industrial as a potential allowable use in waiver request #3.
4. The applicant should coordinate with the Transit Department to ensure proper transit amenities.

5. The applicant should coordinate with the Leisure Services Department to ensure a proper Greenway connection.
6. Although not technically required for E-O zones, due to the varied nature of the proposed uses, raised walkways should be provided throughout the parking areas to provide separation between vehicles and pedestrians. This would be required of similar style developments in other zones, which is the intent of what is proposed in this application.
7. Proposed signage should be removed from the plans since they require a separate review. [Staff notes that most of the illustrated signs would not be allowed and any variance request would be reviewed by the Hearings Board, not the Mayor & Commission.]

II. PLANNING COMMISSION RECOMMENDATION – Pending

III. CURRENT STATUS

The Planning Commission is scheduled to consider the request at their regular meeting on November 9, 2020. At that time, the Planning Commission will review the submitted application and consider a recommendation to “Receive the Preliminary Plan with Comments.” Submittal of a Master Planned Development report and plan will follow a subsequent review cycle schedule.

Report for 100 Newton Bridge Road

Reviewed	Not Applicable	<u>Zoning Criteria for Type II Applications</u>
X		1. The proposed rezoning conforms to the future development map, the general plans for the physical development of Athens-Clarke County, and any master plan or portion thereof adopted by the Mayor and Commission.
	X	2. The proposed special use meets all objective criteria set forth for that use provided in the zoning ordinance and conforms to the purpose and intent of the comprehensive plan and all its elements.
X		3. Public services, which include physical facilities and staff capacity, exist sufficient to service the proposed rezoning.
X		4. The proposed rezoning will not adversely affect the balance of land uses in Athens-Clarke County.
X		5. Existing land use pattern surrounding the property in issue
X		6. Possible creation of an isolated district unrelated to adjacent and nearby districts
X		7. Population density pattern and possible increase or over-taxing of the load on public facilities including, but not limited to, schools, utilities and streets
X		8. The cost of the Unified Government and other governmental entities in providing, improving, increasing or maintaining public utilities, schools, streets and other public safety measures
X		9. The possible impact on the environment, including but not limited to, drainage, soil erosion and sedimentation, flooding, air quality and water quantity
X		10. Whether the proposed zoning amendment will be a deterrent to the value or improvement of development of adjacent property in accordance with existing regulations
X		11. Whether there are substantial reasons why the property cannot be used in accordance with existing zoning; provided, however, evidence that the economic value of the property, as currently zoned, is less than its economic value if rezoned as requested will not alone constitute a significant detriment
X		12. The aesthetic effect of existing and future use of the property as it relates to the surrounding area
X		13. Whether there are other existing or changing conditions affecting the use and development of the property which give supporting grounds for either approval or disapproval of the zoning proposal



Zoning Map of Athens-Clarke County

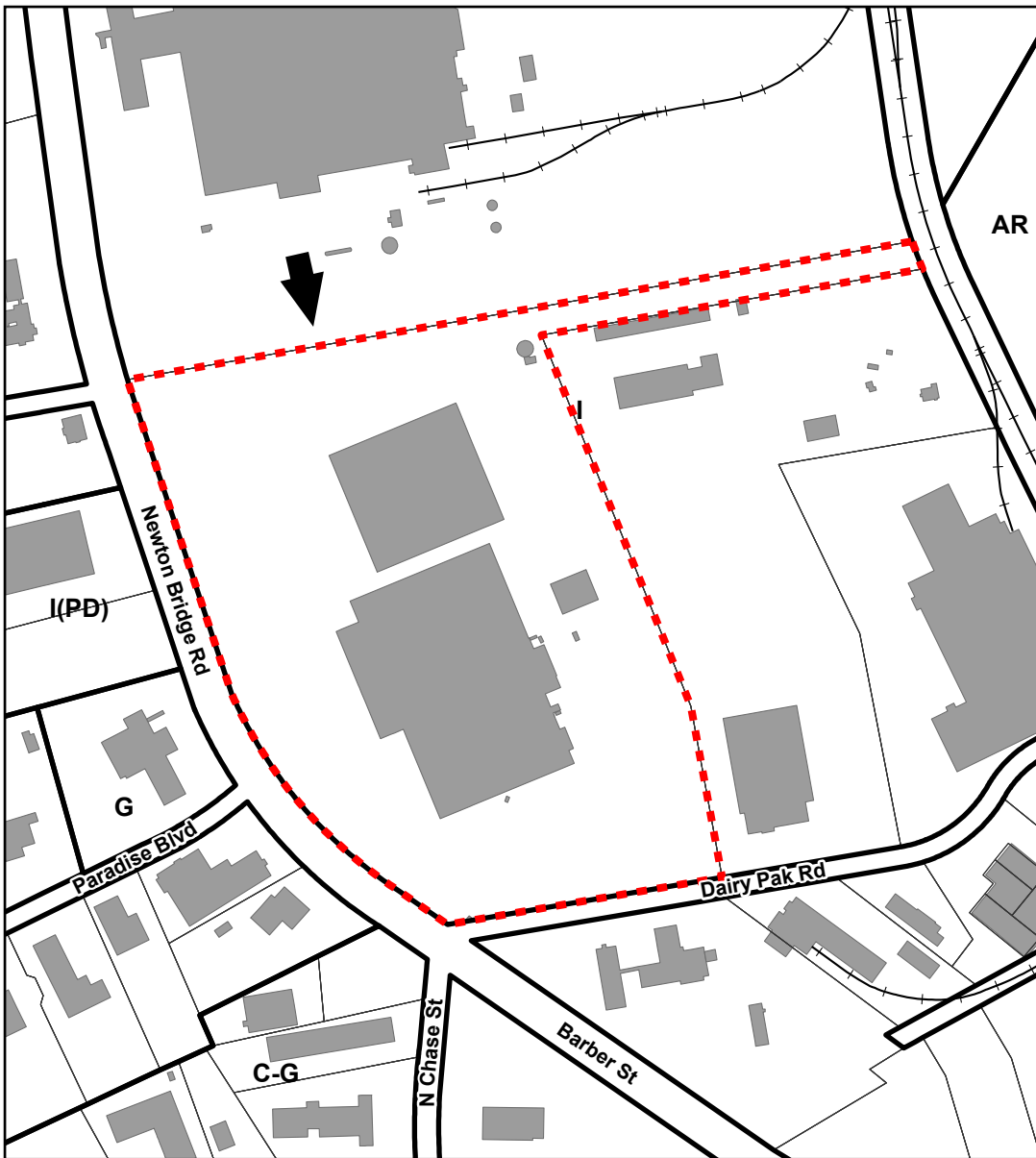

LEGEND

- Site Location
- ACC Zoning
- AR** Agricultural Residential
(1 unit per 10 acre density)
- RS-40** Single Family Residential
(40,000 sq. ft. min. lot area)
- RS-25** Single Family Residential
(25,000 sq. ft. min. lot area)
- RS-15** Single Family Residential
(15,000 sq. ft. min. lot area)
- RS-8** Single Family Residential
(8,000 sq. ft. min. lot area)
- RS-5** Single Family Residential
(5,000 sq. ft. min. lot area)
- RM-1** Mixed Density Residential
(16 multi-family units per acre)
- RM-2** Mixed Density Residential
(24 multi-family units per acre)
- RM-3** Mixed Density Residential
(50 multi-family units per acre)
- G** Government
- P** Parks
- C-G** Commercial General
- C-D** Commercial Downtown
- C-N** Commercial Neighborhood
- C-O** Commercial Office
- C-R** Commercial Rural
- E-O** Employment-Office
- E-I** Employment-Industrial
- I** Industrial
- IN** Institutional
- Downtown Design Area
 - (DHD)** Downtown Historic District
 - (WD)** West Downtown
 - (ED)** East Downtown
 - (DS)** Dougherty Street
 - (RIV)** River
 - (WE)** West End
- RM-LTD, Mixed Density Residential Limited Overlay
- GSRC, Gaines School Road Corridor Special District Overlay
- MAC, Milledge Avenue Corridor Special District Overlay
- WBS, West Broad Street Special District Overlay
- A, Airport Overlay Zone
 - AZ1** Precision Approach Zone
 - AZ2** Larger than Utility Runway Nonprecision Approach Zone
 - AZ3** Utility Runway Nonprecision Approach Zone
 - TZ** Transitional Zone
 - RPZ** Runway Protection Zone
 - PSZ** Primary Surface Zone
- PD, Planned Development
- CSPD, Conservation Subdivision Planned Development
- Zoning with Condition
- Conditional Use
- Special Use
- Local Historic Landmark
- Local Historic District Boundary

Parcel boundaries of the site are determined by legal description. The parcels shown on this map are to be used only as a guide.

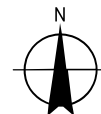

120 0 120
Feet

Type II PD-2020-10-2875 PRELIMINARY PLANNED DEVELOPMENT 100 NEWTON BRIDGE ROAD Ed Lane / Smith Planning Group Westlox Rocks, LLC		FROM: I TO: E-O (PD)
TAX PARCEL #	PLANNING COMMISSION MEETING DATE	ATHENS-CLARKE COUNTY COMMISSION MEETING DATE
112 003	November 9, 2020	TBD

CHAPTER 9-2. DEFINITIONS

Sec. 9-2-1. General.

Retaining wall: A wall or terraced combination of walls used at a grade change to hold soil or other earth material at a higher position. Retaining walls may be attached to or independent from other structures, but do not include the foundations of structures or buildings.

Sec. 9-10-2. Permitted uses.

The following uses and their accessory uses are permitted as shown in the use table below:

<i>Commercial Zoning Districts</i>	<i>C-G General</i>	<i>C-D Downtown</i>	<i>C-O Office</i>	<i>C-N Neighborhood</i>	<i>C-R Rural</i>
Dwellings Above or Below Businesses	P, L(1)	P, L(1)	P, L(1)	P, L(1)	P, L(1)
Multifamily Dwellings	P, L(1)	P, L(1)	P, L(1)	P, L(1)	P, L(1)

L(1) = Permitted only on second story and above or in the basement level of the structure. At least 50 percent of the ground floor shall be leasable commercial space not used for parking, none of the ground floor shall be used for self-service storage, and the commercial space shall be accessed only through a publicly accessible building entrance. Access to residential dwellings shall not be through the designated area comprising the minimum 50% commercial space. Multifamily residential uses arranged in any other manner on a commercially-zoned property are permitted only as a special use permit. For C-D zone properties in the North Downtown, West Downtown or River Downtown Design Areas, ground floor residential uses are permitted subject to the associated design standards found in Section 9-10-6-D(7).

Sec. 9-10-6. Design Standards for “C-D” zone.

- A. Design areas. For the purpose of this title, the C-D zone is divided into design areas as described in the “Alternative Compliance Guidelines for the CD Zone – Athens-Clarke County, Georgia,” (hereinafter “Alternative Compliance Guidelines”), dated June 5, 2007, adopted herein by reference, and available for public inspection in the offices of the Athens-Clarke County Planning Department and the Clerk of Commission.

Downtown Historic District

West Downtown

East Downtown

Dougherty Street

River

West End

North Downtown

B. Design area boundaries. The location and boundaries of the design areas in the Commercial-Downtown (C-D) zoning district listed in paragraph (1) above are delineated on the Official Zoning Map of Athens-Clarke County, Georgia. The Official Zoning Map of Athens-Clarke County, Georgia, constituting the component part of the Zoning Ordinance of Athens-Clarke County, Georgia, by virtue of and in compliance with section 9-3-3 and section 9-3-6 thereof, is hereby amended by adding the boundaries of said design areas within the C-D zoning district, as shown on Attachment A hereto. The date of this amendment to the Official Zoning Map of Athens-Clarke County, as shown by Attachment A, shall be noted on said Official Zoning Map in the Clerk of Commission's office and duly noted in the minutes of the Commission meeting. When uncertainty exists with respect to the location of the boundaries of any design area in the C-D zone, the rules of section 9-3-4, concerning zoning district boundary lines, shall apply in determining design area boundary lines. The boundary limits of individual design areas shall be completely contained within the C-D zone. In the event that a parcel is rezoned to the C-D designation, the Mayor & Commission contemporaneously with such rezoning shall assign a design area to such parcel. Such determination shall be based upon the parcel's proximity to an existing design area and characteristics of the existing design area that are similar to those of the rezoned parcel.

C. Site Design Standards.

1. Maximum building setbacks. The maximum building setback from a property line adjacent to all street rights-of-way (not including alleys) shall be as follows:

Design Area	Maximum Setback	Minimum Wall Percentage ¹
Downtown Historic District	0 feet	70%
West Downtown	0 feet	50%
East Downtown	0 feet	50%
Dougherty Street	Not required 30 feet	Not required 50 %
River	Not required 30 feet	Not required 50 %
West End	30 feet	50%
North Downtown	30 feet	50%

¹The minimum percentage of the front wall plane between the street right-of-way and the maximum building setback line. The maximum length of a wall, set at an angle not exceeding 45 degrees to the street right-of-way and set back further than the maximum front setback line, shall not exceed 50 feet.

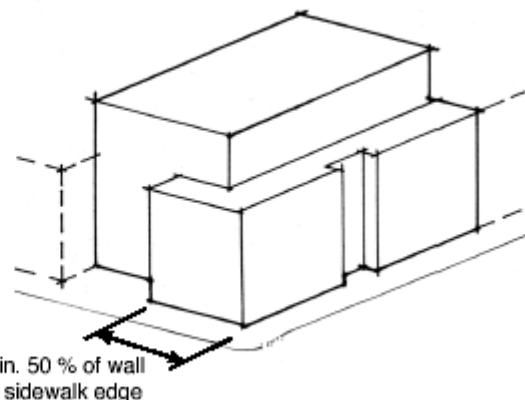
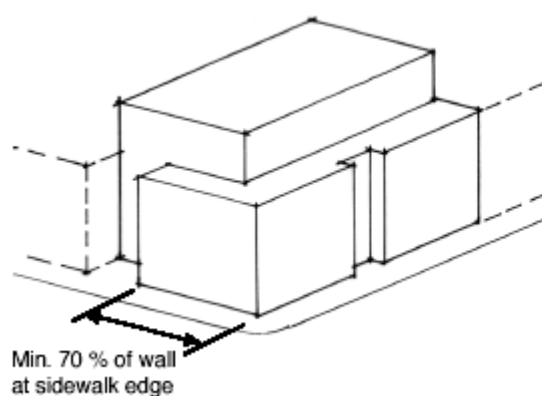

2. Parking structures. Any structured parking shall have leasable and occupiable commercial or residential uses between the property line and parking at street level. These other uses shall extend a minimum of 70% of the linear street frontage of the structure.

3. Surface parking lots.

- a. Accessory surface parking areas shall not be located in the front yard or the side yard adjacent to a street (not including alleys).
- b. A surface parking lot as a principal property use shall comply with the following setback requirements:

Design Area	Min. Street Setback
Historic District	Not Permitted
West Downtown	10 feet
East Downtown	10 feet
Dougherty Street	10 feet
River	10 feet
West End	10 feet
<u>North Downtown</u>	<u>10 feet</u>

- c. A landscape buffer shall have a minimum depth of 10 feet between a street right-of-way (not including alleys) and the parking area. The landscape buffer shall incorporate a sight-obscuring hedge screen, which shall grow to be at least 24 inches and no more than 42 inches higher than the finished grade of the parking area, except for required vision clearance areas. Screen plantings shall be of such size and number to provide the required screening within 12 months after installation. Adequate provisions shall be made to protect plant materials from being damaged by vehicles using the parking area.
- d. Surface parking areas shall be shaded by trees in accordance with section 8-7-15(J).
- e. Raised pedestrian walkways shall be installed through surface parking areas of 50 or more spaces or more than 100 feet in average width or depth.
- f. Surface parking lots with 50 spaces or more shall be divided into separate areas and divided by landscaped areas or walkways at least ten feet in width, or by a building or group of buildings.

4. Public sidewalks shall be provided adjacent to a public street along the street frontage.

5. Trash storage areas, mechanical equipment, and similar areas shall be screened from view from adjacent public rights-of-way.

6. Outdoor storage areas and loading facilities shall be screened from view from adjacent public rights-of-way.

7. Transit amenities, bus shelters, and pullouts shall be required in accordance with the Athens-Clarke County Transit Service.

8. Retaining walls shall be setback from a public right-of-way two feet for every foot of wall height as measured parallel to the right-of-way and accounting for any linear changes in height. No portion of a retaining wall shall exceed ten feet in height. A terrace is required between a lower retaining wall and an upper wall and the terrace area shall have a minimum five foot depth as measured from the upper grade of the lower retaining wall to the base of the upper retaining wall. Retaining walls over five feet in height shall be screened by a landscape buffer meeting the standards of Sec. 9-10-6-D-4(b)(3); however, wall art, including murals, sculptural or other decorative treatment of exterior walls may extend for a maximum of 50% of the wall length. Acceptable materials include, but are not limited to, stucco, split face blocks, slump block, brick, stone, glass blocks, curved interlock blocks, wood, tubular steel, wrought iron bars, other grill work, or a combination of these materials. Exposed flat-face CMU blocks are prohibited

9. Chain-link fencing is not allowed in any yard adjacent to a street..

D. Building Design Standards.

1. Horizontal definition of the building façade. First and second floor levels of a wall of a building that faces a public street shall be horizontally defined with clearly distinguishable horizontal details, which shall extend for a minimum of 70% of the wall length. A horizontal element shall define the first floor and the second floor. The required horizontal articulation may be achieved by using one of the following methods:
 - a. A molding, ornamental trim, window casing or sill that projects a minimum of three inches from the primary wall surface, and/or
 - b. A setback in the primary wall plane at the second and/or third floor level, a minimum of five feet from the floor below, and/or
 - c. A permanently affixed canopy, extending a minimum of four (4) feet from the building face, and/or
 - d. A horizontal fascia that defines floor structure between the first and second floors, and/or
 - e. An eave of a porch, portico, or other similar element, which extends a minimum of 18 inches from the building face.

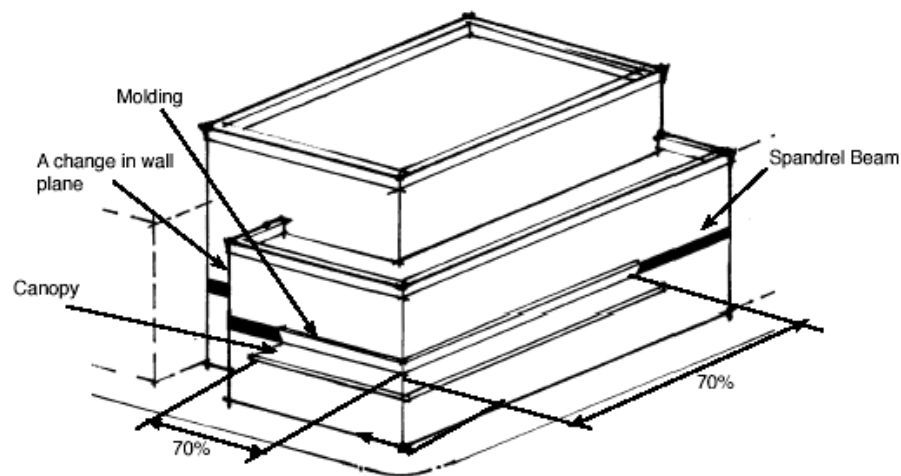

Examples of horizontal definition achieved through use of moldings, changes in wall plane, canopies and a spandrel beam. The moldings and canopies shown would each independently meet the requirement for horizontal articulation extending 70% of the wall length.

2. Vertical definition of building modules. Vertical definition shall be provided at a minimum of every 40 feet of façade length, using one or more of the following methods:
 - a. A molding, ornamental trim, or window casing projecting a minimum of three inches from the primary wall surface and is a minimum of three inches wide, and/or
 - b. A setback in the primary wall plane a minimum of three feet from the building face and for a minimum width of three feet.

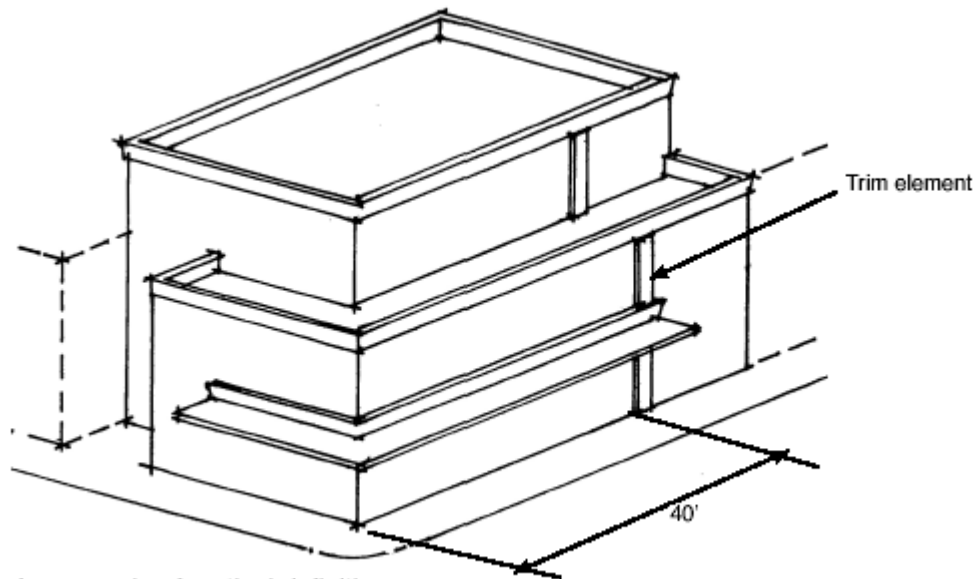

An example of vertical definition

3. Primary entrance. The primary public entrance of a building each ground floor tenant space shall face a street and be directly linked to a public sidewalk, with a maximum allowance of two tenant spaces sharing the same direct link. ~~‡~~ The primary entrance shall be positioned no more than five feet above the finished grade at the front of the building.
 - a. Buildings shall incorporate lighting and changes in mass, surface or finish to give emphasis to entrances.
 - b. Buildings shall incorporate arcades, roofs, alcoves, porticoes and/or awnings at public entrances that protect pedestrians from the rain and sun.
4. Transparency. A minimum percentage of any wall facing a public street shall have openings accounting for the percentages provided below and use transparent glass in those openings, unless directly associated with open unenclosed parking structures, and shall be provided as follows:

Design Area	1 st Floor Street Level	Upper Levels
	min. %	min. %
Downtown Historic District	60%	20%
West Downtown	50%	20%
East Downtown	50%	20%

Dougherty Street	30%	20%
River	30%	20%
West End	30%	20%
North Downtown	30%	20%

- a. Transparency at the street first floor level shall be measured from the finished building grade at the street to 10 feet above grade for the entire width of the wall.
 - b. The following alternative design treatments may be used, singularly or in combination, to meet half of the transparency requirement per elevation at the street level:
 - (1) A display case, defined as a box with transparent glass facing the street with a solid panel behind for display of products and images of goods and services offered in the area.
 - (2) Wall art, including murals, sculptural and other decorative treatment of exterior walls.
 - (3) Landscaping, which is to be at least three feet high at the time of planting and of a type that will produce an opaque, evergreen planting screen capable of growing to a height of at least six feet within three years.
 - c. Windows must allow views into working areas or lobbies, pedestrian entrances or display areas.
5. Building materials. No more than 25% of a wall surface, singularly or in combination, may be of plaster, stucco, or metal sheet siding. Metal siding shall be prohibited on the first floor, except for fabricated architectural metal siding panels with a gauge value of 24 or less and without exposed fasteners after installation is complete.

Plain concrete block (CMU), synthetic stucco (e.g., EFIS), mirror glass, and tinted glass with a tint of 20% gray or greater are prohibited exterior building materials.

6. All properties in the “C-D” zone shall have a minimum floor area (FAR) ratio of 0.40. Expansions of existing development for which at least 50% of the original structure is retained are exempt from the minimum FAR. Plazas and pedestrian areas, conforming to the standards of section 9-25-8-F.2, shall count as floor area for the purpose of meeting the minimum FAR. Reductions of the lot area calculation shall be allowed for flood plain, bodies of open water, wetlands, riparian buffers, slopes greater than 25 percent, buffers required by section 9-15-3, and public utility easements, if these areas remain vegetative or landscaped.

7. Ground-floor dwellings are permitted in the North Downtown, West Downtown and River Downtown Design Areas without a special use permit, subject to the following standards:

- A. The dwellings shall front a local street.
- B. Each ground-floor dwelling shall have direct pedestrian access to the street and public sidewalk.
- C. The dwellings shall have leasable and occupiable commercial space between the property line and the dwellings at street level. The commercial space shall extend a minimum of 70% of the linear street frontage of the structure.
- D. The dwellings shall be a minimum distance of 75 feet from the streets listed below, as measured from the lot line to the nearest street right-of-way.

Broad Street
College Avenue
Lumpkin Street
North Avenue
Oconee Street
Prince Avenue

- E. Alternative Compliance. Except for properties within the Downtown Historic District, applicants may request alternatives to compliance with the design standards of this section through a design review process guided by the separate Alternative Compliance Guidelines for the C-D Zone. Applications for alternative compliance will be processed through the Type III procedure described in Chapter 9-4 (Procedures). The Planning Commission shall review alternative compliance applications in light of any comments received from the public, the intent of the standards of this section, and the applicable design guidelines. An alternative compliance application may be approved upon a finding by the Planning Commission that:
1. The request would result in public benefits greater than any negative impacts; and
 2. The request is consistent with the goals, objectives, and policies set forth in the Comprehensive Plan of Athens-Clarke County; and
 3. The request is consistent with the attributes of the Downtown and of the Design Area described in the Alternative Compliance Guidelines; and
 4. The request conforms to the relevant Alternative Compliance Guidelines.

**Alternative Compliance Guidelines
for the CD Zone
Athens-Clarke County, Georgia
June 5, 2007**



Alternative Compliance Guidelines for the C-D Zone

Athens-Clarke County, Georgia

1.0 General Intent

Design standards for the C-D Zone District in Downtown Athens set forth a series of prescriptive measures for assuring that new buildings and alterations are consistent with the goals, objectives and policies set forth in the Comprehensive Plan for Athens-Clarke County.

New development should be sensitive to the traditional context from which the Downtown has evolved. However, accommodating new development and promoting infill helps to reduce sprawl in outlying areas.

While many projects will simply comply with the standards, there may be situations in which owners seek to use alternative means of achieving the desired results. The code, therefore, provides for an optional design review process, using more discretionary guidelines. This document provides those guidelines, which shall be applied as described below.



1.1 Relationship to goals in the Comprehensive Plan

The Comprehensive Plan for Athens-Clarke County identifies Downtown as a special area, which is to have specific design standards, to “protect the historic character” and also to “insure that new buildings develop in a downtown style and are of sufficient intensity.” The Comprehensive Plan also introduces certain “corridors” in which a preferred character should be promoted through regulations.

1.2 General design principles

The Comprehensive Plan states that the community should “develop and implement design standards for new development and redevelopment that address architectural composition (both material and form), site circulation, site and parking lot landscaping (including tree planting standards for parking lots), lighting and noise level standards.” These standards are further founded on considerations of urban design, which are set forth in the Comprehensive Plan. These include:

- creating a pedestrian-friendly environment
- establishing a sense of visual continuity while encouraging creativity and diversity in individual building designs
- promoting a mix of uses that contributes to vitality of Downtown
- conveying a sense of human scale

1.3 A Vision for Downtown

The community seeks to have these attributes in Downtown Athens:

1.3.1 Downtown is the place of collective memory.

Its buildings, sites and landscape features provide a record of the historical continuum of the community. If the record disappears, the cultural continuum is disrupted. And, while remembering this continuum is important, so is anticipating the future.

1.3.2 Downtown is a place of public expression.

It is where the public goes to speak, to act, and convey who they are. This expression occurs in civic art, architecture, in activities and performances, and in public spaces.

1.3.3 Downtown is a place of human and humane experience.

It is a place people can gather to enjoy a sense of community and be entertained and enlightened.

1.3.4 Downtown is accessible.

Places are linked with safe and convenient systems that encourage movement and interaction. This applies first to the pedestrian, then public transit and non-motorized vehicles, and lastly, vehicular traffic.

1.3.5 Downtown is a place of diversity.

This is true in all senses - demographic, activities, and physical environment. It is inclusive. Downtown is a microcosm of Athens-Clarke County and the diverse cultures of the community.

1.3.6 Downtown is environmentally sustainable.

Buildings are constructed to last, and to make best use of resources. Its framework also supports sustainable commerce and movement.

1.3.7 Downtown is a place of economic vitality and vibrancy.

Downtown is symbolically and factually the economic engine of the community.

1.4 Applicability by Area

These design guidelines are for use in the C-D zone where compliance with design standards is required. The alternative compliance process shall not apply to properties in the Downtown Historic District.

1.5 Applicability by Use

These guidelines apply to a commercial, residential and mixed-use development in the C-D one in which owner seeks to comply with the standards in the code through alternative measures. They also apply to any parking facilities, either surface lots or structures, whether developed as distinct land uses or in conjunction with other uses. In some cases,

staff may also use them in other conditional reviews where design compatibility is a concern.

These guidelines will not apply unless a request for alternative compliance with the design standards has been made.



2.0 The Character of Downtown Athens

Downtown consists of approximately 300 acres that sit above the banks of the Oconee River, in a grid of streets which is slightly skewed from a north-south axis. It is generally bounded by Pulaski Street on the West, Dougherty Street on the North, the Oconee River on the East, and Broad Street on the South. The University of Georgia defines the southern edge.

College Avenue, which runs perpendicular to Broad, generally divides Downtown and was historically a primary commercial street. Clayton also is a primary commercial street, and the intersection of these two streets still conveys the sense of a downtown center. The greatest concentration of traditional commercial storefront buildings lies along Clayton Street, between Thomas and Lumpkin Streets. These are buildings with storefronts at the sidewalk edge, with masonry walls. Other lines of commercial buildings extend outward along downtown streets, but become less intense near the edges of the area.

Downtown also has been the historic center of government, which is reflected by city and county buildings, as well as courts and cultural facilities. It also has a high concentration of churches. All of these institutional buildings add accent to the area and convey its importance as the civic center for the community.

Key gateways into the Downtown occur at the approximate four-corners of the rectangular collection of commercial blocks. Of these, three enter at angles, which afford a special sense of entry into the area (Prince and North Avenues and Oconee Street). Gateways also define the entry points of Broad Street. The street rises from both points into Downtown, providing dramatic views.

The view over the Oconee River is also a noteworthy feature. Since Downtown sits high above the river, view opportunities abound. The northern and western edges of Downtown are framed by older established residential neighborhoods, which are predominantly single family in scale, although some larger multifamily structures exist. These neighborhoods create distinct, green edges to the more urban character of Downtown itself.

3.0 Design Areas

The community's vision for Downtown, which is established in the Comprehensive Plan, is to be pedestrian oriented area with a vital mix of uses and a higher density of development. In general, the C-D zone is to be treated as a single entity, in terms of the application of development standards, but the code does acknowledge some variations, in context. Even so, there are some differences in development patterns that will emerge in response to variations in street patterns, topography, and relationships to abutting zone districts. In order to address these differing conditions, the C-D zone is to be considered in a set of sub-areas:

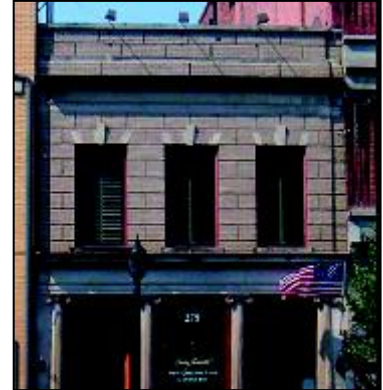

A. Downtown Historic District

This design area is bounded approximately by Hancock, Jackson, Broad and Lumpkin, with some portions extending beyond those streets. See the attached map for the specific boundaries.

This area contains a high concentration of historically significant buildings, and their preservation is a goal. It is anticipated that alterations and additions to historic buildings will occur, and new infill construction may be feasible on some parcels that do not have historic structures. A key design goal for this area is to preserve its historic significance and to assure that new buildings will be compatible with traditional commercial storefront type structures. Objectives are to maintain a clearly defined street edge that is lined with storefronts and other features that provide a sense of human scale and create interest for pedestrians. That is, the edge of the street should be defined with buildings, not with parking lots. Small courtyards and plazas may provide accents along the street, but the line of building fronts should predominate.

This area is a locally-designated historic district, and a Certificate of Appropriateness, issued by the Historic Preservation Commission is required. The design guidelines for the historic district apply to this area.

B. West Downtown Design Area

This area is bounded approximately by Lumpkin, Broad, Pulaski and Hancock. See the attached map for the specific boundaries. It contains a mix of commercial, residential and institutional uses.

This area should be an extension of the Downtown, in terms of the general character of buildings with respect to mass, scale, materials and articulation. It should be a place that invites walking, and supports active retail uses at the street level. It should evolve as a place with a mix of old and new structures, at varied heights. Many new buildings are expected to be more than two stories tall and a relatively high density overall is anticipated.

While West Downtown should feel related to the Downtown Historic District, some greater variety in the streetscape is expected, with plazas and courtyards giving variety to the street edge. Office uses and housing is expected on upper levels.

A design goal for this area is to promote a pedestrian-friendly atmosphere that is experienced as an extension of the Historic Core. The use of buildings with storefronts at the sidewalk edge is encouraged, but some variations in building setbacks and the use of landscaped open space along the street edge is to be accommodated.

Extending the sense of scale found in the historic core and enhancing pedestrian interest are also design objectives for this area, but more flexibility in the methods of achieving this is to be provided. The visual impacts of parking should be minimized, either by enclosing parking in structures, or placing it behind active uses.

C. East Downtown Design Area

This area is bounded approximately by Thomas, Foundry, Broad and Strong Streets, with some portions extending beyond. See the attached map for the specific boundaries. Several new buildings have appeared in East Downtown recently, which have helped to shape its image. Commercial buildings, with retail uses at the street level, provide a framework for defining the street edge with storefronts. A new hotel and residential units are emerging that also have first floors with extensive window area that provide interest. These reinforce a vision of defining the street wall with buildings at the sidewalk edge that convey an urban character.

At the same time, several institutional facilities exist here. They have more formal entries, and include plazas and courtyards that animate the street scene. Therefore, some variation in the character of the street edge is appropriate. However, overall, this is envisioned as a relatively densely built area, with strongly defined sidewalk edges. This area is similar to the West Downtown Design Area, in that it has a strong sense of relatedness to the historic core. A design goal for this area is to promote a pedestrian-friendly atmosphere that is experienced as an extension of the Historic Core.

The use of buildings with storefronts at the sidewalk edge is strongly encouraged, but some variations in building setbacks and the use of landscaped open space along the street edge is to be accommodated. Maintaining the sense of scale found in the historic core and providing pedestrian interest are also design objectives for this area, but somewhat more flexibility in the methods of achieving this is to be allowed.

It is also important to note that portions of this area slope downhill toward the river. This provides some special view opportunities and also modifies the ways in which storefronts align in elevation. Rather than creating a straight line, a “stair-step” effect results when storefronts of similar heights are repeated along a block.

D. Dougherty Street Design Area

This design area lies along Dougherty Street from North Avenue to Pulaski Street. See the attached map for the specific boundaries.

Dougherty Street should develop with an urban edge. At the same time, this is an area where a substantial amount of housing is anticipated. High rise housing may mix with townhouses and other mixed use developments. While much of this may be developed up to the sidewalk, there may also be projects that are set back, with courtyards and small lawns in front. Overall, some variety in the street edge is anticipated. Where buildings are set back, extensive landscaping, and street trees should set the foreground.

This area is relatively undeveloped at present, with large expanses of paved parking lots. It is not pedestrian-friendly at present, and a key objective is to enhance it to create a pedestrian-friendly street edge and to re-build a sense of connection with the historic core.

Locating buildings close to the sidewalk is encouraged here, however, it is anticipated that some new buildings in the area may be set back from the street edge, and will be perceived as individual, stand-alone structures in an open landscape. In such a case, a green, landscaped foreground should predominate. The visual impacts of parking should be minimized, either by enclosing parking in structures, or placing it behind active uses.

E. River Design Area

This area is bounded approximately by Oconee Street, Foundry Street, North Avenue and the river. See the attached map for the specific boundaries.

The River Design Area differs from the others. Steeply sloping hillsides and the river valley combine to create a more informal street pattern and provide unique view opportunities. Many buildings overlook the multi-modal center and others have views to the river. Large expanses of green space also exist, which provide opportunities to orient development to these amenities.

This means that some buildings may be more “free-standing,” rather than sitting in conventional gridded streets. Nonetheless, defining the street edge with buildings and landscaping is an important objective.

Buildings in this area should be designed to orient to the street, but also to natural amenities, including the river and adjoining green space. In this respect, some may be “double-fronted.”

The street edge of such developments also should express visual interest and convey a sense of human scale for pedestrians. However, greater flexibility in the methods of accomplishing this is appropriate here.

While building at the street edge is encouraged, there are many cases where buildings may instead be located in a landscaped setting, as individual structures. It is anticipated that buildings here may be set back from the street edge. In such a case, a green, landscaped foreground should predominate. The appearance of cars parked in both structures and surface lots are to be minimized when viewed from the street and the river edge. This also is an area where providing pedestrian connections between properties is an objective; providing connections to regional trails is also desirable.

Overall, buildings in this area should maintain a sense of open space and provide through views to landmarks and natural amenities. Development should also reflect the topography of the area, by stepping building forms.

F. West End Design Area

This design area is bounded approximately by Pulaski, Prince, Finley and Broad Streets, with another portion extending on the south side of Broad from Lumpkin to Newton and south until Wray Street. See the attached map for the specific boundaries. The West End area is anticipated to develop with a substantial amount of residential units, although some commercial uses and additional institutional facilities may also occur. Apartment buildings, townhouses and high rise mixed use developments will create a mix of building forms, and there may be more variety in the character of the street edge in this area.

This area has a mix of residential, commercial and institutional buildings. Many are free-standing structures, framed by yards and other landscaped areas. Varied setbacks are appropriate. It is anticipated that some buildings may be set back from the street edge. In such a case, a green, landscaped foreground should predominate. The visual appearance of parked cars, both in surface lots and in potential structures, is to be minimized.

It is also important to note that the West End design area abuts residential zones, and providing compatible transitions along these edges is an objective. Many buildings are institutional, and are “freestanding,” with formal front entries. These add accent to the urban fabric, but are not considered the context for new residential and commercial infill development; for infill of these uses, buildings that are positioned closer to the street are preferred.

G. North Downtown Design Area

This design area is bounded approximately by North Hull Street, the railroad, Thomas N. Lay Park and Strong Street, one block north of Dougherty Street. See the attached map for the specific boundaries. The North Downtown area is anticipated to develop with a substantial amount of residential units. Apartment buildings, townhouses and high rise mixed use developments will create a mix of building forms, and there may be more variety in the character of the street edge in this area. However, buildings should be

oriented to and positioned closer to College Avenue, a collector street and the only street in the design area not classified as a local street.

This area has a mix of residential, commercial, governmental and institutional buildings. Many are free-standing structures, framed by yards and other landscaped areas. Varied setbacks are appropriate. It is anticipated that some buildings may be set back from the street edge. In such a case, a green, landscaped foreground should predominate. Development should also reflect the topography of the area, by stepping building forms. The visual appearance of parked cars, both in surface lots and in potential structures, is to be minimized. Key objectives are to create a pedestrian-friendly street edge and to build a sense of connection with the rest of Downtown.

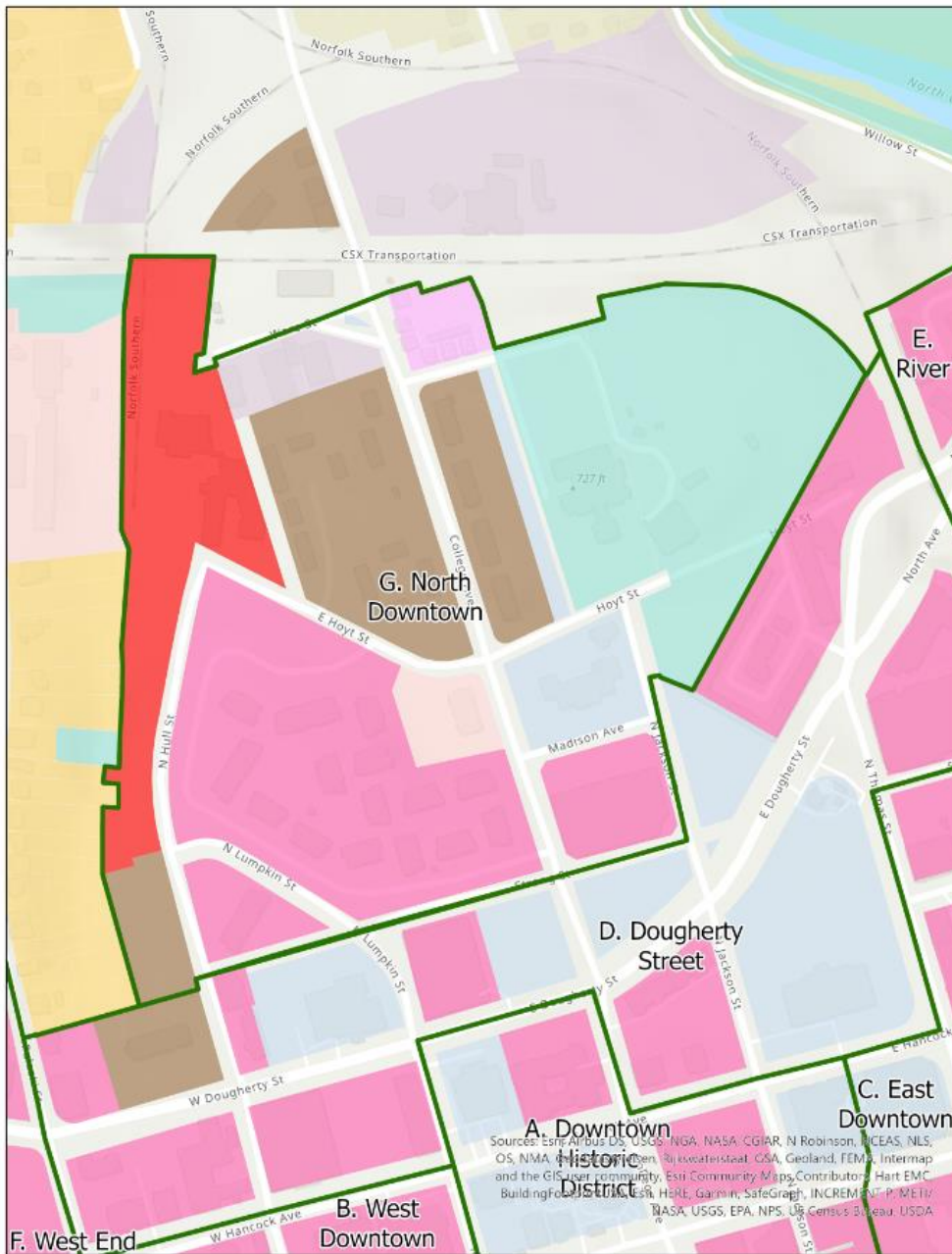

3.1 Application of the Design Areas in the Design Guidelines

The preceding descriptions of the design areas and the general vision for each of them are to be considered when applying the design guidelines for alternative compliance situations.

4.0 Site Design Guidelines

4.1 Building Setbacks

The Zoning and Development Standards establish a requirement for building setbacks in the C-D zone. The setback requirements are defined for each of the Design Areas in the design standards. There is a minimum and maximum setback with a minimum percentage of front wall plane that must be at the required setback line. The intent is to create a sense of human scale and provide visual interest to pedestrians while also expressing the distinctions of the different Design Areas.

In most cases, the primary plane of the building should be at the required building line. However, setbacks may be modified if the intent of the standard is maintained as described below.

4.1.1. Define the building plane at the required front setback with architectural elements.

Imply a building plane at the standard setback line by providing structural features at the street level that suggest a storefront composition.



This building front has variations in its depth. A planter serves to define the front line at the sidewalk edge.



This building front also has variations in its depth. Steel columns define the building face at the sidewalk edge.

4.1.2. Contribute to the character of the street edge with open space.

The minimum length of building front that must be at the required setback may be reduced if it can be demonstrated that the resulting open space would contribute positively to the character of the street edge.

4.2 Parking Structures

In the Zoning and Development Standards, a parking structure is required to have a “wrap” of other uses to maintain a traditional street edge. Commercial space is the typical design solution, since it provides a pedestrian friendly and active edge.

The standards mandate that a minimum of 70% of a building face on a parking structure be “wrapped” with other uses. However, there may be some cases in which site constraints make it impractical to do so. To the greatest extent feasible, this standard should be met. However, when it is not possible to meet the standard, a portion of the required active use may be substituted with other features that meet the intent of the standard by providing visual interest and a sense of scale as described at right.

4.2.1 Design the street edge of a parking structure to provide interest to pedestrians.

The ground floor of a building should be composed of one or more of the following:

- display windows
- display cases
- architectural details
- public amenities
- wall art

4.2.2 Design alley sides of parking structures to be visually interesting.

Where a “wrap” of active uses is not practical, consider lining the ground floor alley sides of parking structures with visually interesting architectural screens.

4.2.3 Design the upper floors of parking structures to be visually interesting.

Where a parking structure is not “wrapped” or extends above a “wrap”, architectural elements including grills, railings and murals, should



Parking structures designed to provide interest to pedestrians at the street edge. Upper floors are screened with architectural grills, railings and murals.



4.3 Surface Parking Lots

Section 9-25-8(E) of the Athens-Clarke County Codes requires surface parking lots to be sited in combination with active uses. The standards also require a landscape buffer of a planting density described in Section 9-25-8 and Section 8-7-15(J) of the Athens-Clarke County Code.

The intent of the standards is to minimize the visual impact of parked cars and ensure a pedestrian friendly environment. If this intent is met, the width and planting density of the required landscape buffer may be altered as described below.

4.3.1. Provide a visual buffer between surface parking lots and public rights-of-way.

Use a combination of landscape and structural elements to meet the intent of the planting density requirement. Buffer surface parking lots with uses that can animate the street edge.

4.4 Buffers & Connections

Providing connections between residential and commercial uses is encouraged. If a pathway or other connection is provided to link neighborhood serving commercial uses with an adjacent residential neighborhood, an exception to buffering requirements may be considered as follows.



A surface parking lot is screened with a combination of trees, a low hedge, a metal fence and stone piers.



A stone wall, metal fence and trees screen a surface parking lot while an automated teller machine helps animate the street edge.

4.4.1. Provide and enhance pedestrian connections between abutting properties.

When access would be beneficial, use one or more of the following elements:

- landscaped pedestrian paths
- plaza or public art walk

5.0 Building Design Standards

5.1 Horizontal Definition of Building Facades

The standards define prescriptive measures for establishing horizontal definition of building facades with the intent of conveying a similar scale at the first and second floor levels of buildings. The specific measures used to achieve horizontal definition may be varied through design review providing that the resulting design is compatible with the intent of the standards.

If the intent of the standards is maintained, the depth of the required molding may be modified, or the distance of a required wall setback may be adjusted. In addition, other methods of creating a horizontal definition may be considered, as provided below.

5.1.1. Define the first and second floors with clearly distinguishable horizontal details.

This can be achieved with one or more of the following:

- change in material
- change in wall plane
- change in color
- change in texture or pattern
- architectural panels



Alternative methods of achieving a horizontal definition:

1. *Upper left - A change in materials and a wall plane setback at the second floor level*
2. *Lower left - Banding at the first floor level created by a change in material and texture*
3. *Upper right - A change in material and color at the first floor level*
4. *Lower right - A horizontal molding and canopy at the first floor level and a spandrel and line of window sills at the second floor level*

5.2 Vertical Definition of Building Modules

The Zoning and Development Standards mandate an articulation of vertical elements that reflect the scale of traditional buildings downtown. This encourages a pedestrian-friendly environment by establishing a rhythm of building modules along the street.

Prescriptive measures are defined in the code. However, the intent of the standards may be achieved in other ways. The dimensions of the prescribed options for vertical elements may be modified if the intent of the requirement can be met as described below.

5.2.1. Buildings should appear similar in width to those seen traditionally.

This can be achieved by one or more of the following:

- change in material

- variations in wall planes
- change in color
- change in texture or pattern
- architectural detailing



*Vertical definition accomplished in a variety of ways:
 Top Left photo: varied setbacks in wall planes, emphasized in some cases with decorative trim elements (quoins).
 Bottom Left Photo: Notches in the building wall establish a definition, even though they do not extend down to the street level.
 Right photo: Projecting balconies and windows aligned vertically achieve a vertical definition in this building*

5.3 Primary Entrance

The primary entrance of a building should, ideally, face the street to match traditional building patterns and encourage pedestrian access. However, the entry may be offset or oriented differently, if it is clearly defined from the street and other elements provide a sense of connection with the street.

5.3.1 Define the primary entrance of a building from the street.

This can be implied by the following:

- recessed entrance with the door located perpendicular to the sidewalk
- entrance court
- other methods that imply a front building entrance on the street



*A large inset defines the primary entrance to this building. Note also how the emphasis of the first floor columns helps to achieve a definition of vertical modules.
(Bozeman, MT)*



This canopy defines the primary entrance. Notice also how a horizontal articulation is achieved with moldings and a change in materials

5.4 Transparency

A minimum percentage of glass is prescribed in the standards for walls that face a public way. The intent of the standards is to maintain the sense of visual continuity along the street, provide interest to pedestrians and contribute to a traditional sense of scale. If the design intent is maintained, the prescribed transparency percentages may be modified as follows.

5.4.1 Maintain the apparent solid-to-void ratios of facades seen on traditional commercial and residential buildings in the area.

This can be achieved using one or more of the following techniques:

- lower areas of transparency can be appropriate on upper floors if the building detail implies horizontally and/or fenestration is achieved with other means
- larger areas of transparency can be appropriate if they are located above the first floor or highlight an entrance.

5.4.2 For walls that face secondary public ways, consider a reduced percentage of transparency.

Alternative methods that may be used to provide a sense of traditional scale and visual interest include:

- display windows
- display cases
- architectural details
- public amenities
- landscaping
- signs



Variations in transparency may be appropriate where the overall sense of scale and visual interest is achieved.



Landscaping, combined with articulation of materials along a secondary wall, may be considered in some circumstances. This would not be appropriate along a primary street frontage.



Display cases and murals may sometimes be used on secondary walls.



Preferred percentage of transparency

5.5 Building Materials

Because traditional masonry materials exhibit the desired sense of texture, they are the preferred building materials. However, other materials may be appropriate in limited amounts if they are sufficiently detailed to exhibit the sense of scale, texture and interest traditionally provided by masonry materials. To do so, substitute materials must include details with enough depth to create noticeable shadow lines and variations in texture and color.

The minimum percentage of permitted materials may be modified if the overall intent of maintaining visual continuity and a sense of traditional scale along the street is maintained as follows.

5.5.1 New building materials should provide the visual interest traditionally provided by masonry.

This can be achieved by one or more of the following:

- a change in texture or pattern
- a change in color
- architectural detailing

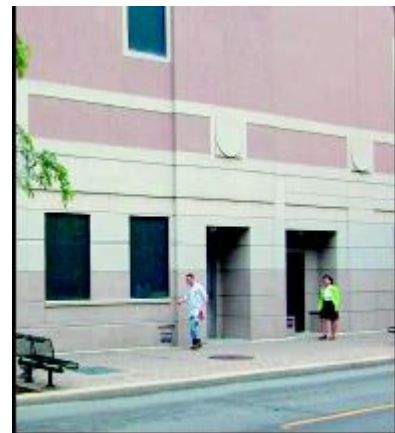

In these examples, synthetic stone, cast concrete and stucco are used. Scoring joints, moldings, and contrasting trim elements help to create texture and scale.

Additional Design Examples



Transparency



Vertical articulation a combination of material changes and pilasters



Variations in wall plane create vertical expression



Architectural metal cladding used in limited amount



Vertical articulation



Horizontal emphasis created by canopy overhang



Building composed of a “base, middle and cap,” which establishes a horizontal expression



Horizontal definition of first floor; second floor with intermittent balconies



Alternative materials